

THE MOTION YOU TRUST

2023

# DRAWER SLIDE SYSTEMS

FOR PROFESSIONAL APPLICATIONS





2023

# **DRAWER SLIDE SYSTEMS**

FOR PROFESSIONAL APPLICATIONS

Roller Bearing Drawer Slide Systems  
Vertical Pantry Pull-Out Slide Systems  
Stainless Steel Roller Bearing Drawer Slide Systems  
Ball Bearing Drawer Slides



**I N N O V A T I O N S**



# Innovative Product Solutions

FILTERER is positioned in the global market and known as a leading manufacturer of robust and reliable drawer slide systems. Innovation driven product development occurs through close engagement with key equipment producers in a wide variety of industries and demanding applications.

Continuous investments into state-of-the-art manufacturing equipment and tooling technology contribute to meet highest quality standards and cost efficiency.

FILTERER does provide the widest range of drawer slide systems in its product portfolio. Even more FILTERER's product design and engineering team is highly committed to create customized product solutions tailored to a specific application requirement. In the in-house global R&D center motivated engineers create the ideal product in conjunction with customers and consumers. Flexibility and quick responsiveness by utilizing rapid prototyping solutions resulting in innovative new products and continuous product improvements. All new products are thoroughly performance and endurance tested in the advanced on-site testing laboratories prior to release in mass production.

**Q U A L I T Y**





### **TÜV AUSTRIA – Quality management**

All FULTERER manufacturing locations are certified according to EN ISO 9001 standards. Continuous investments into tooling equipment, testing and measuring technology are contributing to meet best-in-class product quality and highest efficiency.



### **RoHS**

'Restriction of the use of certain Hazardous Substances' is the directive on the use of certain hazardous substances. Our products comply with the RoHS directive and are manufactured in compliance with the latest EU regulations.



### **REACH**

The company policy is to use only materials and processes which comply with the REACH Regulation. As a down-stream user, we have asked our suppliers to deliver us products according to the REACH Regulation and 'if necessary' to pre-register these products. We have asked our suppliers, when they, or their suppliers, don't pre-register to inform us and to offer a replacement for that product according to the REACH Regulation.



### **NSF (National Sanitation Foundation)**

All FULTERER stainless steel drawer slide systems are NSF-tested and meet the highest hygiene standards for public health and safety in the food processing industry.



### **ÖKOPROFIT Vorarlberg**

ÖKOPROFIT is a certification for process-oriented environmental management. ÖKOPROFIT primarily focuses on the company's environmental programme, waste disposal strategy, energy, environmental performance indicators and reporting (for environmental and business success), environment-related laws and regulations, informing/training of employees and continuous optimisations (e.g. mobility). An annual audit is performed to confirm whether the ÖKOPROFIT requirements are being met, following which a new certificate is issued.



### **CALIFORNIA PROP 65**

**WARNING:** This product can expose you to chemicals including nickel, which is known to the State of California to cause cancer and birth defects or other reproductive harm. For more information go [www.P65Warnings.ca.gov](http://www.P65Warnings.ca.gov).



## MARKET PRESENCE

Generally FULTERER products are marketed directly to Original Equipment Manufacturers.

FULTERER staff and distribution partners are available to you in worldwide six wholly owned locations in Austria, Switzerland, USA, China, Mexico, Brazil and regional distributors globally. Application experts provide engineering support to determine the ideal product for each individual application.

## PRODUCT PORTFOLIO

Our drawer slide systems are categorised into the following product groups:

- **Roller Bearing Drawer Slide Systems:**  
The roller components consists of either synthetic rollers, steel ball bearings or synthetic encased steel ball bearings.
- **Ball Bearing Drawer Slides:**  
The runner unit design is based of steel balls caged in a retainer.
- **Vertical Pantry Pull-Out Slide Systems**

## LOAD CAPACITY

Generally, the load capacity is indicated by the values for the highest permissible dynamic load. The load capacity is factored of load weight, slide extension, and lifetime expectation respective number of duty-cycles. One duty-cycle is equal to one entire opening and closing of a drawer.

Attention: These values only apply with the use of suitable fasteners at all intended fastening positions. For the following dimensions, the specified load capacity values of each drawer slide system with the highest permissible dynamic load are:

- **Roller bearing drawer slides for 600 mm / 23.62 in. extension length and 450 mm / 17.72 in. drawer width.**
- **Ball bearing drawer slides for 450 mm / 17.72 in. extension length and 450 mm / 17.72 in. drawer width.**
- **In case of longer extension length (up to 1,000 mm / 39.37 in.), the load capacity is reduced by approx. 20 %.**
- **Roller Bearing Drawer Slide Systems:**  
FULTERER roller bearing drawer slide systems meet the dynamic test requirements of at least **50,000 cycles** at standard lengths of **600 mm / 23.62 in.** and standard mounting type under full rated load capacity.
- **Ball Bearing Drawer Slides:**  
FULTERER ball bearing drawer slides meet the dynamic test requirements of at least **50,000 cycles** at standard lengths of **450 mm / 17.72 in.** and standard mounting type under full rated load capacity.





## MOUNTING OPTIONS

Besides various standard solutions also customized designs for the installation of drawer slide systems are available:

- **Mounting holes:** round, elongated or key-hole. Always in the centre of the profile, so that the screw heads do not interfere with rollers.
- **Bayonet tabs:** rapid assembly method for fitting of drawer slide systems to sheet metal cabinets and fixtures. Several types and sizes are available.
- **Hanging hooks:** a fast method of assembly of drawer slide systems to cabinets. An angle bracket on the cabinet profile hooks into a pilaster rail in the side of the cabinet.

## INSTALLATION

**Cabinet profile:** Drawer slide systems are attached to the **side wall** of the cabinet with screws or mounting tabs on an inside wall of a cabinet, mostly using the 32 mm pitch.

### Drawer profile:

- **Bottom mount:** The bottom edge of the drawer side is resting in the flange of the drawer profile. Both roller and ball bearing slides are available in this style.
- **Side mount:** The drawer profile is attached to the side of the drawer side or pull-out shelf. Both roller and ball bearing drawer slides are available in this style.

## CLOSING METHODS

**Self-closing (by gravity):** Predominately with roller bearing slides where both cabinet and drawer profile are shaped on an angle at the rear to let the drawer roll closed in the last part of the closing travel.

**ECD Automatic self-closing with anti-slamming Easy Close Device (ECD):**  
This feature prevents the drawer from slamming shut by absorbing the initial closing force via a damping cylinder and utilizing aspring mechanism to complete the closing cycle with a very smooth and quiet closing action.

# INDEX

Type	Model	max. Load Capacity kg / lbs.	Built-In Width mm / in.	Mounting	Page
<b>ROLLER BEARING DRAWER SLIDE SYSTEMS</b>					
<b>Regular extension</b>	FR 2021	35 / 80	12.0 / 0.47	bottom mount	<b>12</b>
	FR 2071	70 / 155	15.0 / 0.59	bottom mount	<b>13</b>
	FR 206	100 / 220	16.0 / 0.63	bottom mount	<b>14</b>
	FR 206 ECD	100 / 220	16.0 / 0.63	bottom mount	<b>15</b>
	FR 216	100 / 220	24.0 / 0.95	bottom mount	<b>16</b>
	FR 9000	200 / 441	56.0 / 2.20	bottom & side mount	<b>17</b>
<b>Full extension</b>	FR 6500	50 / 110	12.0 / 0.47	bottom mount	<b>19</b>
	FR 7180	200 / 441	24.0 / 0.95	bottom mount	<b>20</b>
<b>Accessories</b>	FULFIX II (Mounting Jig)				<b>21</b>
	FR 8001 ECD (Easy Close Device)	30 / 66	12.0 / 0.47	side mount	<b>22</b>
	FR 8003 ECD (Easy Close Device)	70 / 155	12.0 / 0.47	side mount	<b>23</b>
<b>VERTICAL PANTRY PULL-OUT SLIDE SYSTEMS</b>					
<b>Regular extension</b>	FR 505-T	80 / 176	73.0 / 2.87	top mount	<b>26</b>
<b>Full extension</b>	FR 775A ECD	75 / 165	88.5 / 3.48	floor & top mount	<b>27</b>
	FR 771A	120 / 265	108.0 / 4.25	floor & top mount	<b>28</b>
	FR 777A	200 / 441	124.0 / 4.88	floor & top mount	<b>29</b>
<b>Accessories</b>	FR 771A ECD (Easy Close Device)				<b>30</b>
	FR 777A ECD (Easy Close Device)				<b>31</b>
<b>STAINLESS STEEL ROLLER BEARING DRAWER SLIDE SYSTEMS</b>					
<b>Regular extension</b>	FR 1051 SCC	50 / 110	15.0 / 0.59	side mount	<b>34</b>
	FR 1052 SCC	50 / 110	18.0 / 0.71	side mount	<b>35</b>
	FR 1052 SCC SC	50 / 110	18.0 / 0.71	side mount	<b>36</b>
	FR 2051 SCC	50 / 110	15.0 / 0.59	bottom mount	<b>37</b>
	FR 505 SCC	100 / 220	15.0 / 0.59	bottom mount	<b>38</b>
<b>Full extension</b>	FR 6010 SCC	50 / 110	15.0 / 0.59	side mount	<b>39</b>
	FR 785 SCC	60, 48 / 132, 106	18.0 / 0.71	side mount	<b>40</b>
	FR 785 SCC SC	60, 48 / 132, 106	18.0 / 0.71	side mount	<b>41</b>
	FR 786 SCC ECD	60, 48 / 132, 106	18.0 / 0.71	bottom mount	<b>42</b>
	FR 790 SCC	68, 53 / 150, 120	18.0 / 0.71	side mount	<b>43</b>
	FR 790 SCC SC	68, 53 / 150, 120	18.0 / 0.71	side mount	<b>44</b>
	FR 791 SCC	68, 53 / 150, 120	18.0 / 0.71	bottom mount	<b>45</b>
	FR 7100 SCC	120, 105 / 265, 231	24.0 / 0.94	bottom mount	<b>46</b>
	FR 7101 SCC	120, 105 / 265, 231	24.0 / 0.94	side mount	<b>47</b>
<b>Accessories</b>	ECD 79 (Easy Close Device)				<b>48</b>
	FR 712 CNS (Locking System)				<b>49</b>

Type	Model	max. Load Capacity kg / lbs.	Built-In Width mm / in.	Mounting	Page
<b>BALL BEARING DRAWER SLIDES</b>					
<b>Full extension</b>	FR 5000	45 / 100	13.0 / 0.51	side mount	<b>52</b>
	FR 5001 ECD	45 / 100	12.8 / 0.50	side mount	<b>53</b>
	FR 5002 CNS	45 / 100	13.1 / 0.52	side mount	<b>54</b>
	FR 5036	30 / 100	13.0 / 0.51	side mount	<b>55</b>
	FR 5052	90 / 198	13.0 / 0.51	side mount	<b>56</b>
	FR 5400	250 / 550	19.5 / 0.77	side mount	<b>57</b>
	FR 5400L	250 / 550	19.5 / 0.77	side mount	<b>58</b>
	FR 5426 OE	350 / 770	26.0 / 1.02	side mount	<b>59</b>
	FR 5432 OE	220 / 485	32.0 / 1.26	side mount	<b>60</b>
	FR 5439	500 / 1,100	39.0 / 1.54	side mount	<b>61</b>
	FR 5609	100 / 220	19.1 / 0.75	side mount	<b>62</b>
	FR 5609 ECD	80 / 176	19.1 / 0.75	side mount	<b>63</b>
	FR 5826	300 / 660	26.0 / 1.02	side mount	<b>64</b>
<b>Two-way regular extension</b>	FR 5328	400 / 882	13.0 / 0.51	side mount	<b>65</b>
<b>Accessories</b>	FR 5000 ASW (Side Mount Bracket)		14.0 / 0.55	side mount	<b>66</b>
	FR 5400 ASW (Side Mount Bracket)	250 / 550		side mount	<b>67</b>
	FR 8100 (Locking Handle)				<b>68</b>

**Regular extension drawer slide systems**, the drawers **cannot be completely extended**; part of it remains in the cabinet. Regular extension drawer slide systems are a **low-cost, economical solution**.

**Product features:**

- dynamic load capacity from 30 to 100 kg / 66 to 220 lbs.
- nominal lengths from 300 to 1,500 mm / 11.81 to 59.06 in.
- powder coated or galvanised surface

**Full extension drawer slide systems**, the drawer can be **fully extended**, with over extension even beyond the front edge of the cabinet.

**Progressive action drawer slide systems** provide the smoothest running performance. The load in the drawer is equally supported during the full stroke from close to open and vice versa. **Telescopic action full extension drawer slide systems** function incrementally through stages.

**Product features:**

- high dynamic load capacity from 30 to 200 kg / 66 to 441 lbs
- nominal lengths from 200 to 1,200 mm / 7.87 to 47.24 in.
- powder coated or galvanised surface

Regular and full extension drawer slide systems are available in customized design.



A close-up, grayscale photograph of a roller bearing drawer slide system. The image shows a white plastic roller wheel mounted on a metal track. The background is a dark, out-of-focus surface, likely the interior of a cabinet or drawer. The lighting highlights the texture of the metal and the smooth surface of the roller.

12 | 23





# **ROLLER BEARING DRAWER SLIDE SYSTEMS**

- REGULAR EXTENSION
- FULL EXTENSION
- ACCESSORIES

# FR 2021 | Regular Extension Drawer Slide with Lateral Stability



## Specifications

-  bottom mount
-  12.0 mm / 0.47 in.
-  dynamic up to 35 kg / 80 lbs.
-  solid synthetic rollers
-  steel, powder coated

## Characteristics

- integrated side adjustment – clearance adjustable up to 2 mm (0.08 in.)
- double hole system on cabinet profile for offset attachment to thin inside walls
- oblong holes in the cabinet profile permit easy height adjustments
- out stop detent
- single-sided captive profile (left)
- self-closing
- compatible with full extension drawer slide FR 6500 and pitch of 32 mm (1.26 in.)
- optional cabinet profile with synthetic stop

## Dimensions

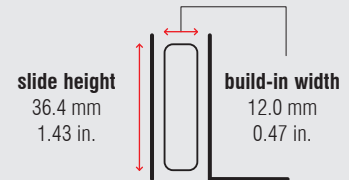

Length		Extension		Weight		Item No.
				per set		pure white
mm	inch	mm	inch	kg	lbs.	
300	11.81	215	8.46	0.50	1.11	<b>7065</b>
350	13.78	265	10.43	0.58	1.27	<b>7066</b>
400	15.75	300	11.81	0.67	1.47	<b>7067</b>
450	17.72	350	13.78	0.73	1.61	<b>7068</b>
500	19.69	400	15.75	0.82	1.81	<b>7069</b>
550	21.65	430	16.93	0.91	2.00	<b>7070</b>
600	23.62	480	18.90	0.99	2.19	<b>7071</b>
650	25.59	530	20.87	1.09	2.41	<b>7072</b>
700	27.56	560	22.05	1.17	2.58	<b>7082</b>

Packing Unit – Sets per Box, all Lengths: 20

# FR 2071

Regular Extension Drawer Slide  
with Lateral Stability



### Specifications

-  bottom mount
-  15.0 mm / 0.59 in.
-  dynamic up to 70 kg / 155 lbs.
-  synthetic silent roller
-  steel, powder coated

### Characteristics

- cabinet profile with synthetic stop
- out stop detent
- single-sided captive profile (right)
- self-closing

### Dimensions

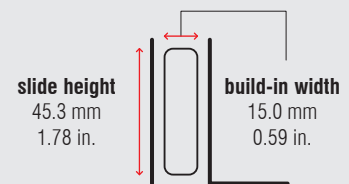

Length		Extension		Weight		Item No.
				per set		pure white
mm	inch	mm	inch	kg	lbs.	
300	11.81	212	8.35	0.86	1.90	1349
350	13.78	262	10.31	1.09	2.40	1350
400	15.75	302	11.89	1.13	2.49	1351
450	17.72	352	13.86	1.27	2.79	1352
500	19.69	402	15.83	1.41	3.12	1353
550	21.65	432	17.01	1.54	3.40	1354
600	23.62	482	18.98	1.69	3.73	1355
650	25.59	532	20.94	1.83	4.04	1356
700	27.56	582	22.91	1.97	4.34	1357
750	29.53	612	24.09	2.10	4.64	1358
800	31.50	662	26.06	2.25	4.95	1359
850	33.46	712	28.03	2.41	5.32	1360
900	35.43	742	29.21	2.52	5.55	1361
950	37.40	792	31.18	2.61	5.75	1362
1,000	39.37	842	33.15	2.81	6.18	1363





Packing Unit – Sets per Box, all Lengths: 10

# FR 206

## Regular Extension Drawer Slide



### Specifications

-  bottom mount
-  16.0 mm / 0.63 in.
-  dynamic up to 100 kg / 220 lbs.
-  steel ball bearings or solid synthetic rollers
-  steel, zinc plated or powder coated

### Characteristics

- stay-closed feature
- out stop detent
- steel rear stop
- zinc plated – steel ball bearings  
powder coated – solid synthetic rollers

### Dimensions

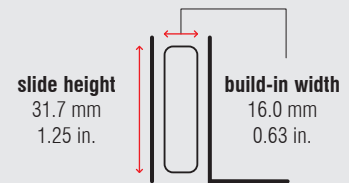

Length		Extension		Weight		Item No.	Item No.
				per set		zinc plated	pure white
mm	inch	mm	inch	kg	lbs.		
300	11.81	209	8.23	1.41	3.10	<b>4064</b>	*
350	13.78	259	10.20	1.64	3.60	<b>4065</b>	<b>4079</b>
400	15.75	294	11.57	1.86	4.09	<b>4066</b>	<b>4080</b>
450	17.72	344	13.54	2.10	4.62	<b>4067</b>	<b>4081</b>
500	19.69	394	15.51	2.32	5.10	<b>4068</b>	<b>4082</b>
550	21.65	444	17.48	2.55	5.62	<b>4069</b>	<b>4083</b>
600	23.62	494	19.45	2.76	6.08	<b>4070</b>	<b>4084</b>
650	25.59	544	21.42	2.97	6.55	<b>4071</b>	<b>4085</b>
700	27.56	564	22.20	3.23	7.12	<b>4072</b>	<b>4086</b>
750	29.53	614	24.17	3.41	7.51	<b>4073</b>	*
800	31.50	654	25.75	3.66	8.07	<b>4074</b>	<b>4087</b>
850	33.46	704	27.72	3.96	8.72	<b>4075</b>	*
900	35.43	744	29.29	4.18	9.22	<b>4076</b>	<b>4088</b>
950	37.40	794	31.26	4.39	9.68	<b>4077</b>	*
1,000	39.37	834	32.83	4.64	10.22	<b>4078</b>	<b>4089</b>

Packing Unit – Sets per Box: from 300 to 550 mm: **10** | from 600 to 1,000 mm: **7**

\* on request



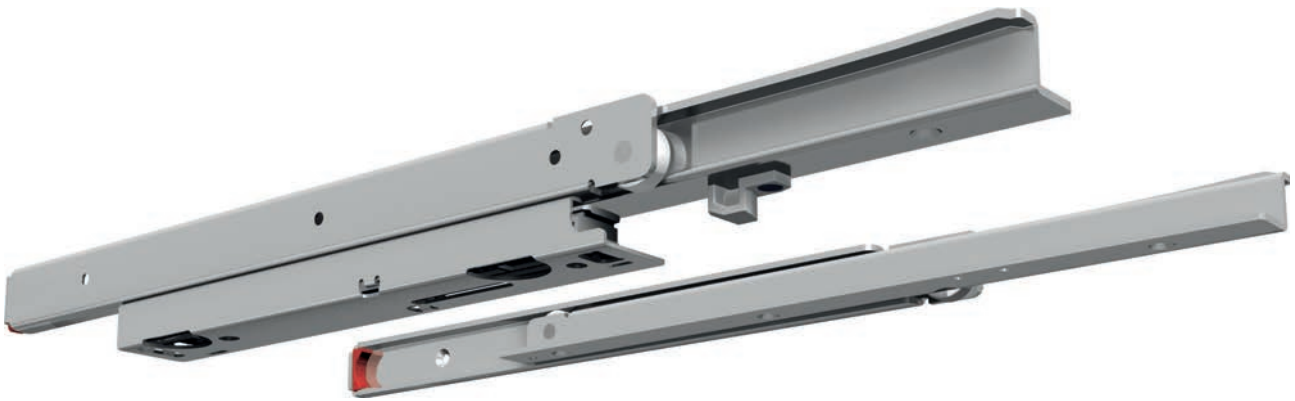

### Specifications

- bottom mount
- 16.0 mm / 0.63 in.
- dynamic up to 100 kg / 220 lbs.
- steel ball bearings
- steel, zinc plated

### Characteristics

- stay-closed feature
- out stop detent
- cabinet profile with synthetic stop

### Dimensions

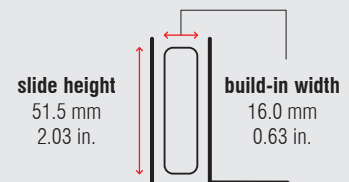

Length		Extension		Weight		Item No.
				per set		zinc plated
mm	inch	mm	inch	kg	lbs.	
400	15.75	294	11.57	2.25	4.96	4303
450	17.72	344	13.54	2.48	5.47	4304
500	19.69	394	15.51	2.71	5.97	4305
550	21.65	444	17.48	2.93	6.45	4306
600	23.62	494	19.45	3.15	6.94	4307
650	25.59	544	21.42	3.38	7.44	4308
700	27.56	564	22.20	3.63	7.99	4309
750	29.53	614	24.17	*	*	*
800	31.50	654	25.75	4.08	8.98	4311
850	33.46	704	27.72	*	*	*
900	35.43	744	29.29	4.53	9.98	4313
950	37.40	794	31.26	*	*	*
1,000	39.37	834	32.83	5.08	11.21	4315

Packing Unit – Sets per Box, all Lengths: 2





\* on request

# FR 216

## Regular Extension Drawer Slide



### Specifications

-  bottom mount
-  24.0 mm / 0.95 in.
-  dynamic up to 100 kg / 220 lbs.
-  synthetic encased steel ball bearings
-  steel, powder coated or zinc plated

### Characteristics

- world's strongest regular extension drawer slide with a load capacity of 100 kg (220 lbs.) up to a length of 1,500 mm (59.06 in.)
- dual ball bearings for more stability and longevity
- dual-sided captive profile
- cabinet profile with synthetic stop

### Dimensions

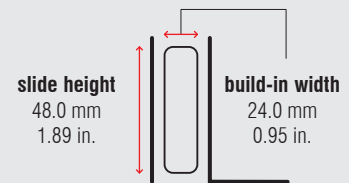

Length		Extension		Weight		Item No.	Item No.	Item No.
				per set		zinc plated	black	white aluminium
mm	inch	mm	inch	kg	lbs.			
600	23.62	460	18.11	3.44	7.59	*	*	4001
650	25.59	500	19.69	*	*	*	*	*
700	27.56	540	21.26	3.98	8.78	*	*	4003
750	29.53	580	22.83	*	*	*	*	*
800	31.50	620	24.41	4.57	10.07	*	*	4005
850	33.46	660	25.98	*	*	*	*	*
900	35.43	700	27.56	5.11	11.26	*	*	4007
950	37.40	740	29.13	*	*	*	*	*
1,000	39.37	780	30.71	5.65	12.46	*	*	4009
1,050	41.34	820	32.28	*	*	*	*	*
1,100	43.31	860	33.86	*	*	*	*	*
1,150	45.28	900	35.43	*	*	*	*	*
1,200	47.24	940	37.01	7.25	15.98	*	*	4013
1,250	49.21	970	38.19	*	*	*	*	*
1,300	51.18	1,010	39.76	*	*	*	*	*
1,350	53.15	1,050	41.34	*	*	*	*	*
1,400	55.12	1,080	42.52	*	*	*	*	*
1,450	57.09	1,120	44.09	*	*	*	*	*
1,500	59.06	1,160	45.67	8.93	19.68	*	*	4019

Packing Unit – Sets per Box: from 600 to 750 mm: **5** | from 800 to 1,000 mm: **4** | from 1,050 to 1,500 mm: **2**

\* on request

# FR 9000

## Regular Extension Aluminium Drawer Slide



### Specifications

-  cabinet profile
-  drawer profile
-  56.0 mm / 2.20 in.
-  dynamic up to 200 kg / 441 lbs.
-  solid synthetic rollers and synthetic encased steel ball bearings
-  aluminium

### Characteristics

- modular sliding system for a wide variety of applications
- The special interior shape of the profile compensates installation inaccuracies in width, height and angular direction.
- centerline groove to mark the holes
- The system FR 9000 can be obtained completely assembled or all parts individually to be fabricated by the user enabling to produce odd sizes with the individual components.

### Dimensions

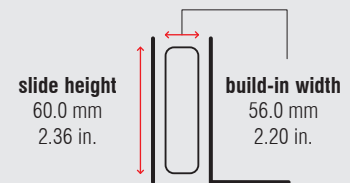

Length		Extension		Item No.	Length		Extension		Item No.
mm	inch	mm	inch		mm	inch	mm	inch	
450	17.72	315	12.40	*	1,300	51.18	910	35.83	*
500	19.69	350	13.78	*	1,400	55.12	980	38.58	*
550	21.65	385	15.16	*	1,500	59.06	1,050	41.34	*
600	23.62	420	16.54	*	1,600	62.99	1,120	44.09	*
650	25.59	455	17.91	*	1,700	66.93	1,190	46.85	*
700	27.56	490	19.29	*	1,800	70.87	1,260	49.61	*
750	29.53	525	20.67	*	1,900	74.80	1,330	52.36	*
800	31.50	560	22.05	*	2,000	78.74	1,400	55.12	*
850	33.46	595	23.43	*	2,100	82.68	1,470	57.87	*
900	35.43	630	24.80	*	2,200	86.61	1,540	60.63	*
950	37.40	665	26.18	*	2,300	90.55	1,610	63.39	*
1,000	39.37	700	27.56	*	2,400	94.49	1,680	66.14	*
1,100	43.31	770	30.31	*	2,500	98.43	1,750	68.90	*
1,200	47.24	840	33.07	*					

Minimum order quantity, pricing and lead time on request

\* on request



### Example FR 9000 Regular Extension

- 2 outer profiles with 4 stops and 2 carriers
- 2 inner profiles with 2 carriers
- all profiles have the same length, extension to one side



### Example FR 9000 Regular Extension

- 2 outer profiles with 4 stops
- 2 inner profiles with 4 carriers
- different lengths of profiles, extension to both sides

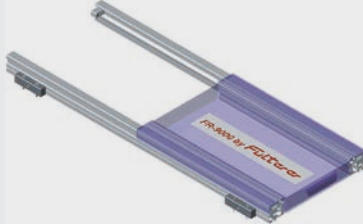

### Example FR 9000 Table Extension

- 2 outer profiles with 6 stops
- table top with carriers arranged in pairs

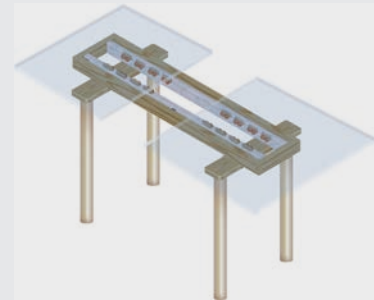

### Individual Components for Fabricators

Individual Components for Fabricators		Item No.
Extruded Profile	Length 6,140 mm / 242 in.	9201
Set for Regular Extension	2 pcs. tolerance compensating roller carriers (red), 2 pcs. ball bearing carriers (white), 4 pcs. stops, 16 pcs. M6x20mm bolts (DIN7984), 24 pcs. M6 square nuts (DIN557)	9200

Assembled Regular Extension Slide	Length		Extension		Weight		Item No.
	mm	inch	mm	inch	per set		
FR 9000	1,600	62.99	1,120	44.10	kg	lbs.	*
FR 9000	1,900	74.80	1,330	52.36	*	*	*
FR 9000	2,300	90.55	1,610	63.39	*	*	*

Minimum order quantity, pricing and lead time on request

\* on request



# FR 6500

## Over Extension Telescopic Action Drawer Slide



### Specifications

-  bottom mount
-  12 mm / 0.47 in.
-  dynamic up to 50 kg / 110 lbs.
-  solid synthetic rollers, synthetic silent rollers
-  steel, powder coated

### Characteristics

- lateral stability
- absorbing soft stop and lift out prevention clip installed
- easy mounting and removal of middle profile
- with standard over extension
- dual-sided captive profile
- self-closing
- compatible with regular extension drawer slide FR 2021 and pitch of 32 mm (1.26 in.)

### Dimensions

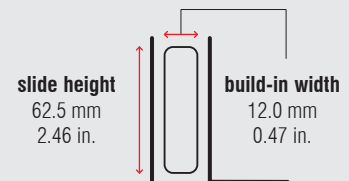





Length		Extension		Weight		Item No.
				per set		pure white
mm	inch	mm	inch	kg	lbs.	
200	7.87	200	7.87	0.70	1.54	1200
250	9.84	250	9.84	0.87	1.92	1201
300	11.81	320	12.60	1.03	2.27	1202
350	13.78	370	14.57	1.21	2.66	1203
400	15.75	420	16.54	1.37	3.02	1204
450	17.72	470	18.50	1.55	3.41	1205
500	19.69	550	21.65	1.74	3.83	1206
550	21.65	570	22.44	1.93	4.25	1207
600	23.62	620	24.41	2.11	4.64	1208
650	25.59	670	26.38	2.48	5.47	1260
700	27.56	750	29.53	2.60	5.73	1261
750	29.53	770	30.31	2.86	6.31	1262
800	31.50	820	32.28	3.06	6.75	1263

Packing Unit – Sets per Box, all Lengths: 10

# FR 7180 | Full Extension Progressive Action Drawer Slide



## Specifications

-  bottom mount
-  24.0 mm / 0.95 in.
-  dynamic up to 200 kg / 441 lbs. (full extension)
-  solid synthetic rollers
-  steel, zinc plated or powder coated

## Characteristics

- high lateral stability
- ideal running characteristic and smoothness of running through integrated progressive action
- integrated safety clip
- dual-sided captive profile
- self-closing

## Dimensions

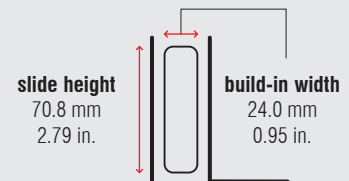

Length		Extension		Weight		Item No.	Item No.
		full extension		per set		zinc plated	lightgrey
mm	inch	mm	inch	kg	lbs.		
400	15.75	385	15.16	3.64	8.02	7150	*
450	17.72	435	17.13	4.11	9.06	7151	*
500	19.69	485	19.09	4.57	10.08	7152	*
550	21.65	535	21.06	5.04	11.11	7153	*
600	23.62	585	23.03	5.50	12.13	7154	*
650	25.59	635	25.00	5.97	13.16	7155	*
700	27.56	685	26.97	6.43	14.18	7156	*
750	29.53	735	28.94	6.90	15.21	7157	*
800	31.50	785	30.91	7.36	16.23	7158	*
850	33.46	835	32.87	7.83	17.26	7159	*
900	35.43	885	34.84	8.29	18.28	7160	*
950	37.40	935	36.81	8.76	19.31	7161	*
1,000	39.37	985	38.78	9.22	20.33	7162	7182
1,200	47.24	1,185	46.65	11.50	25.35	*	7184

Packing Unit – Sets per Box: from 400 to 600 mm: 4 | from 650 to 1,000 mm: 2 | 1,200 mm: 1

\* on request

# FULFIX II | Mounting Jig

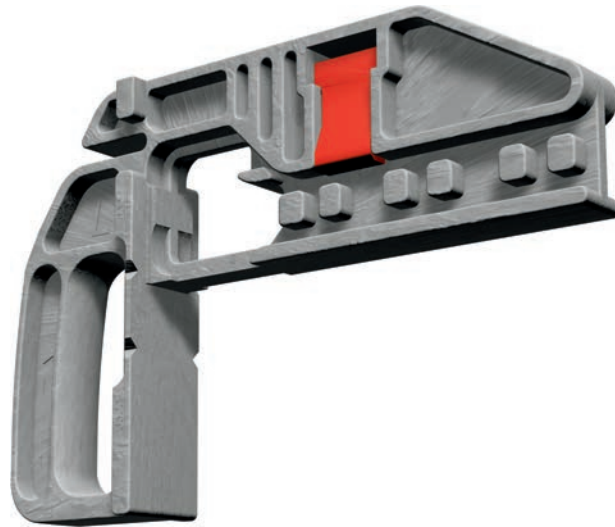

## Specifications

-  synthetic material

## Characteristics

- suited for the cabinet profiles of FR 2021 and FR 6500
- clamping device assures a perpendicular and square fit onto the cabinet side
- for overlay or insert drawer fronts (19 mm / 0.75 in. setback)

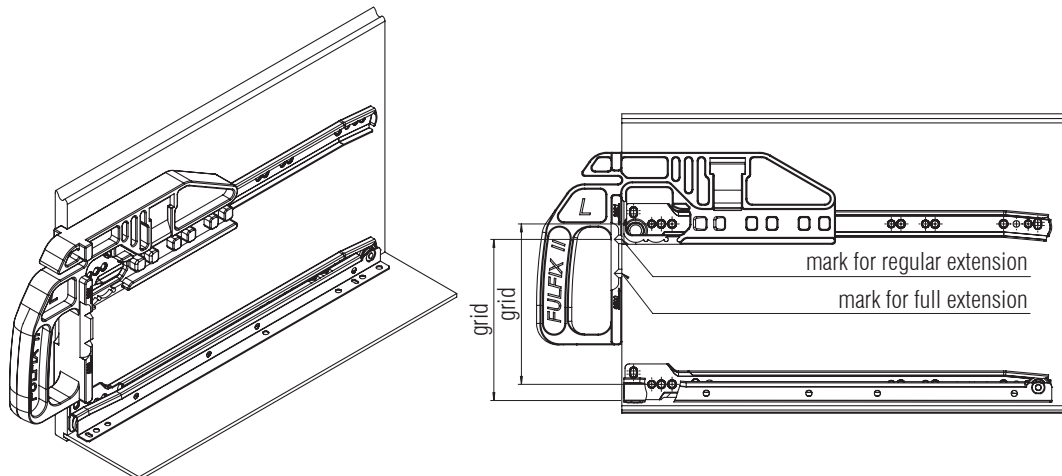

Designation	Weight		Item No.
	kg	lbs.	
FULFIX II	0.34	0.75	3000

Packing Unit – Piece: 1

# FR 8001 ECD | Easy Close Device for Regular Extension Drawer Slides

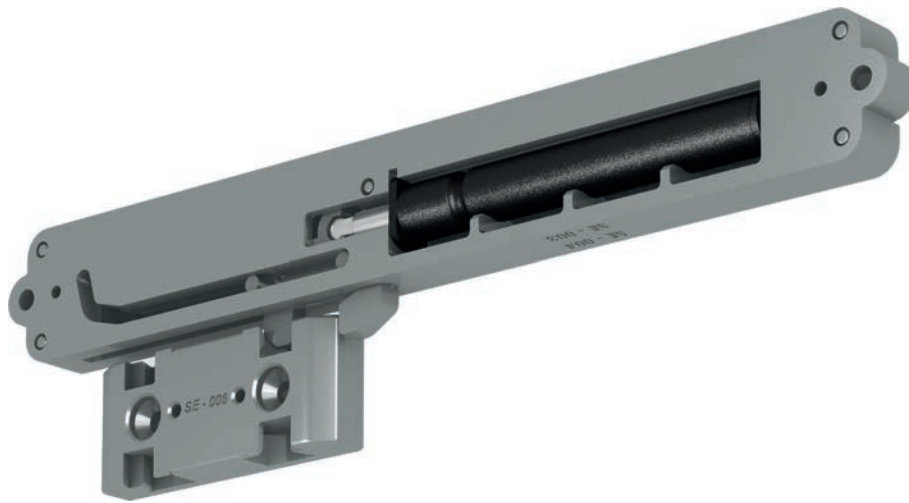

## Specifications

-  side mount
-  12.0 mm / 0.47 in.
-  dynamic up to 30 kg / 66 lbs.
-  synthetic material, steel
-  +10 °C to +40 °C  
+50 °F to +104 °F

## Characteristics

- can be used in combination with any drawer slide with a minimum of 12 mm (0.47 in.) side clearance
- drawer is softly pulled shut from approximately 30 mm (1.18 in.)

## Delivery Set

- 2 pieces spring and damping cylinder
- 2 pieces latch
- 1 piece mounting instruction
- 1 piece mounting set

mounting diagram

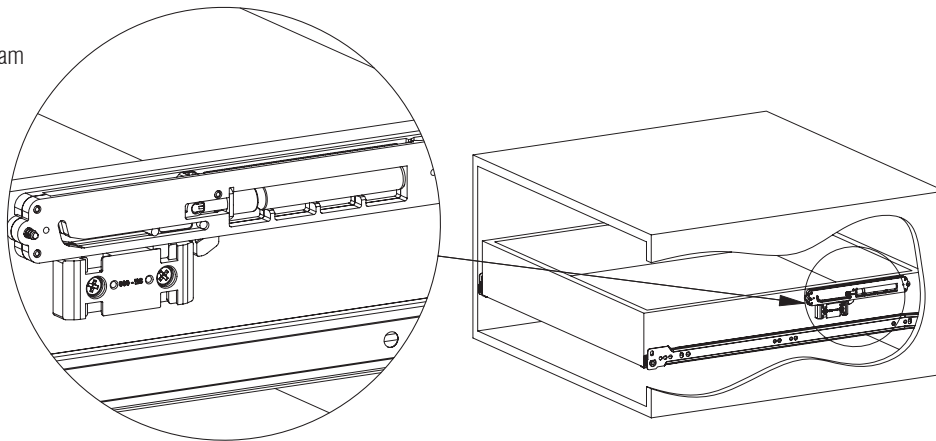

Designation

FR 8001 ECD

Item No.



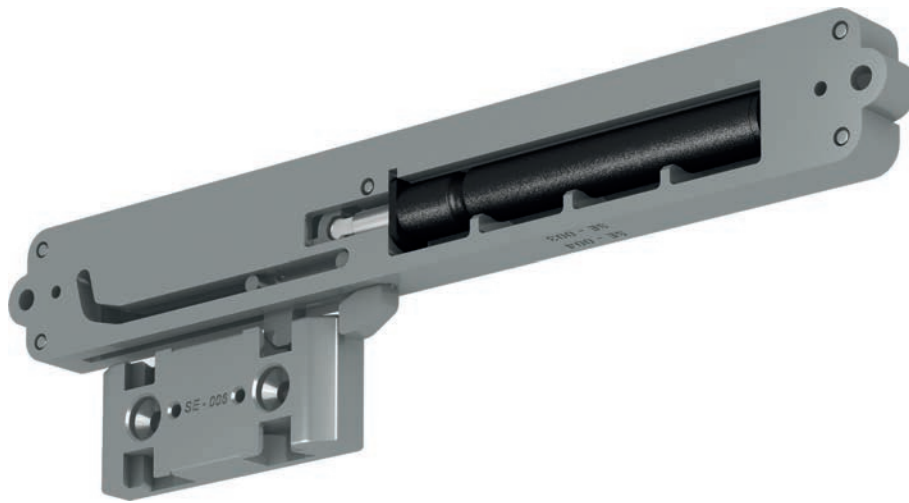

8001

Packing Unit – Set per Box: 1

# FR 8003 ECD | Easy Close Device for Regular Extension Drawer Slides



## Specifications

-  side mount
-  12.0 mm / 0.47 in.
-  dynamic up to 70 kg / 155 lbs.
-  synthetic material, steel
-  +5 °C to +40 °C  
+41 °F to +104 °F

## Characteristics

- can be used in combination with any drawer slide with a minimum of 12 mm (0.47 in.) side clearance
- drawer is softly pulled shut from approximately 30 mm (1.18 in.)

## Delivery Set

- 2 pieces spring and damping cylinder
- 2 pieces latch
- 1 piece mounting instruction
- 1 piece mounting set

mounting diagram

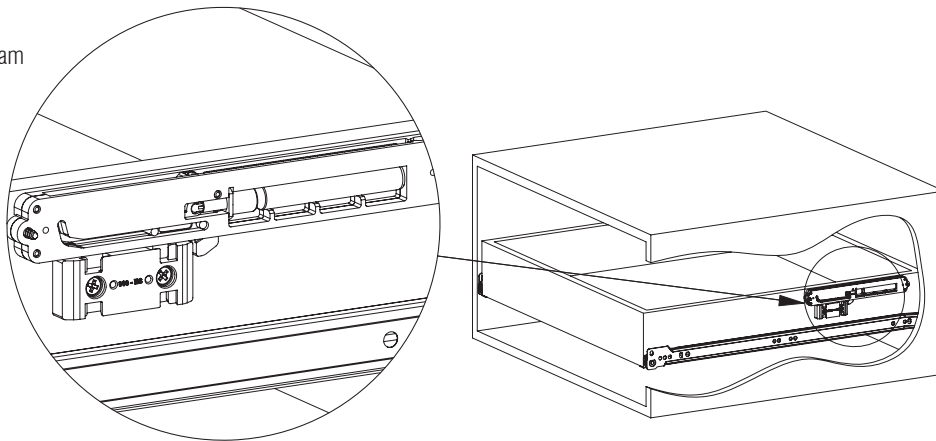

### Designation

FR 8003 ECD cold-resistant

### Item No.

8003

Packing Unit – Set per Box: 1

In addition to the standard product range, FULTERER does offer a wide variety to meet your **individual customized applications**. We work closely with customers and provide **expertise and application know-how** in partnership collaborations.

The **regular extension vertical pull-out slide system FR 505-T** for ceiling-mounting has a load capacity of up to 80 kg / 176 lbs. and is the optimum solution for the attachment of display boards in show-rooms and product display areas.

The **full extension progressive action vertical pull-out slide systems FR 775A ECD, FR 771A and FR 777A** are perfect systems for pull-out cupboards in home, kitchen, pharmacy and laboratory applications, as well as for archive cabinets and vertical cupboards for office furniture.



26 | 31

# VERTICAL PANTRY PULL-OUT SLIDE SYSTEMS

- REGULAR EXTENSION
- FULL EXTENSION
- ACCESSORIES







# FR 505-T

Door Display Slide  
Regular Extension Vertical Pull-Out Slide



## Specifications

-  top mount
-  min. 73.0 mm / 2.87 in.
-  dynamic up to 80 kg / 176 lbs.
-  synthetic encased steel ball bearings
-  steel, powder coated

## Characteristics

- for use in all types of showrooms and shops with display walls, door panels etc.
- lateral stability
- light, rigid and silent movement via special roller assembly
- simple assembly via countersunk fixing holes for M6 countersunk screws
- built-in friction stop in the closed and extended position

## Dimensions

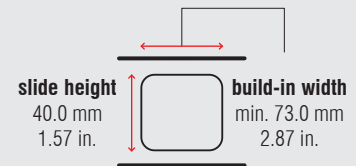

Length		Extension		Weight		Item No.	Item No.
		full extension		per set		black	pure white
mm	inch	mm	inch	kg	lbs.		
450	19.69	340	13.39	*	*	*	*
500	19.69	375	14.76	*	*	*	*
600	23.62	450	17.72	*	*	*	*
700	27.56	525	20.67	*	*	*	*
800	31.50	600	23.62	*	*	*	*
900	35.43	675	26.57	*	*	*	*
995	39.17	750	29.53	5.73	12.63	<b>80134</b>	*
1,050	41.34	790	31.10	*	*	*	*
1,100	43.31	825	32.48	*	*	*	*

Packing Unit – Sets per Box, all Lengths: 4

\* on request

# FR 775A ECD

Full Extension Progressive Action Vertical Pantry Pull-Out Slide System with Top Guide – up to 75 kg / 165 lbs.

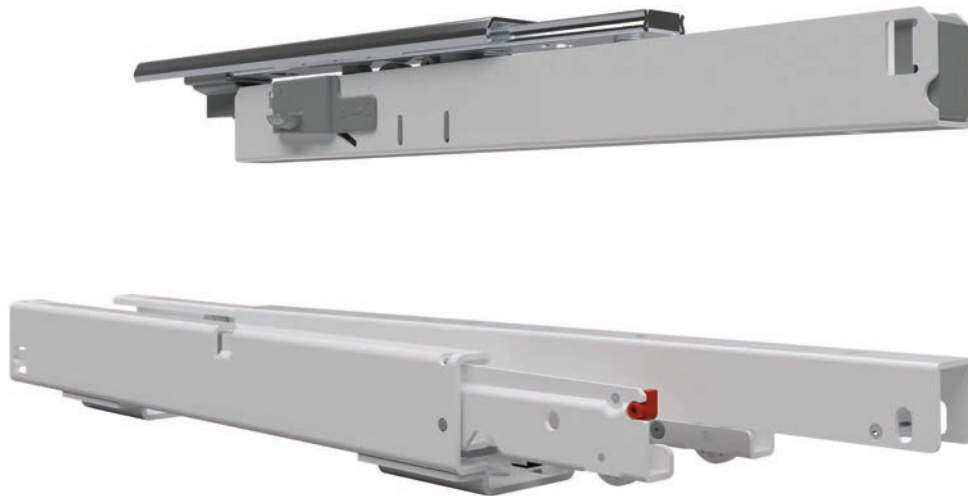

## Specifications

-  floor mount
-  min. 88.5 mm / 3.48 in.
-  dynamic up to 75 kg / 165 lbs.
-  solid synthetic rollers
-  steel, powder coated

## Characteristics

- quick and easy installation through patented slide-on system
- integrated lateral and height adjustment
- recommended maximal cabinet height: 1,500 mm (59.06 in.)
- recommended maximum cabinet width: 400 mm (15.75 in.)

## Dimensions

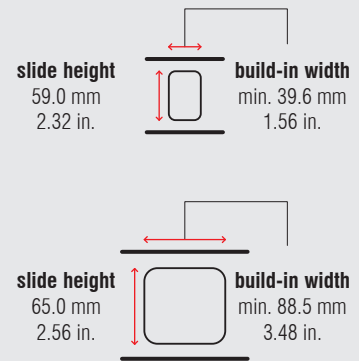

Length		Extension		Weight		Item No.
				per set		pure white
mm	inch	mm	inch	kg	lbs.	
400	15.75	385	15.16	5.67	12.50	4221
450	17.72	435	17.13	6.19	13.64	4222
500	19.69	485	19.09	6.89	15.19	4223
550	21.65	535	21.06	7.41	16.34	4224
600	23.62	585	23.03	8.12	17.89	4225
650	25.59	635	25.00	8.64	19.04	4226
700	27.56	685	26.97	9.16	20.19	4227
750	29.53	735	28.94	9.68	21.33	4228

Packing Unit – Sets per Box, all Lengths: 1

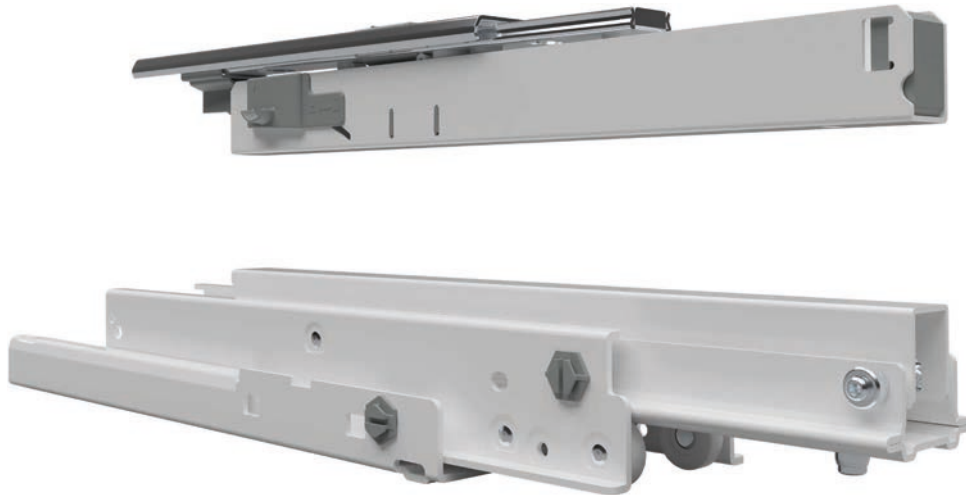

### Specifications

-  floor mount
-  min. 108.0 mm / 4.25 in.  
min. 135.0 mm / 5.31 in. (ECD)
-  dynamic up to 120 kg / 265 lbs.
-  solid synthetic rollers,  
synthetic encased steel ball bearings
-  steel, powder coated

### Characteristics

- deflection in extended and loaded position maximum 5 mm (0.20 in.)
- quick and easy installation through patented slide-on system
- integrated lateral and height adjustment
- Easy Close Device FR 771A ECD can be ordered optionally; Item No. 7749
- LGA-tested according to DIN 4554 at 50,000 cycles
- recommended maximal cabinet height: 2,000 mm (78.75 in.)
- recommended maximum cabinet width: 500 mm (19.69 in.)

### Dimensions

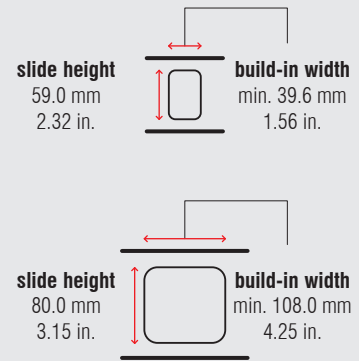

Length		Extension		Weight		Item No.
				per set		pure white
mm	inch	mm	inch	kg	lbs.	
400	15.75	384	15.12	6.85	15.10	7741
430	16.93	414	16.30	*	*	*
450	17.72	434	17.09	7.52	16.58	7742
480	18.90	464	18.27	*	*	*
500	19.69	484	19.06	8.38	18.47	7743
550	21.65	534	21.02	9.05	19.96	7744
575	22.64	559	22.01	*	*	83187
600	23.62	584	22.99	9.77	21.54	7745
650	25.59	634	24.96	10.44	23.02	7746
700	27.56	684	26.93	11.11	24.50	7747
750	29.53	734	28.90	11.79	25.98	7748

Packing Unit – Sets per Box, all Lengths: 1

\* on request

# FR 777A

Full Extension Progressive Action Vertical Pantry Pull-Out Slide System with Top Guide – up to 200 kg / 441 lbs.



## Specifications

-  floor mount
-  min. 124.0 mm / 4.88 in.  
min. 158.0 mm / 6.22 in. (ECD)
-  dynamic up to 200 kg / 441 lbs.
-  solid synthetic rollers,  
synthetic encased steel ball bearings
-  steel, powder coated

## Characteristics

- no deflection in fully extended position
- quick and easy installation through patented slide-on system
- integrated lateral and height adjustment
- Easy Close Device FR 777A ECD can be ordered optionally; Item No. 7719
- recommended maximal cabinet height: 2,500 mm (98.43 in.)
- recommended maximum cabinet width: 600 mm (23.62 in.)

## Dimensions

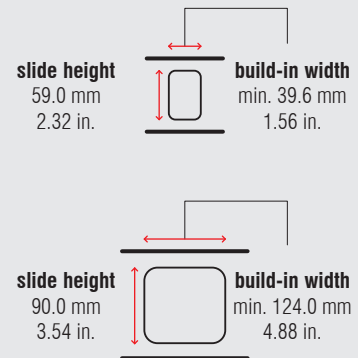

Length		Extension		Weight		Item No.
				per set		pure white
mm	inch	mm	inch	kg	lbs.	
400	15.75	384	15.12	10.39	22.92	7700
450	17.72	434	17.09	11.53	25.42	7701
500	19.69	484	19.06	12.69	27.98	7702
550	21.65	534	21.02	13.81	30.46	7703
600	23.62	584	22.99	14.83	32.69	7704
650	25.59	634	24.96	15.81	34.84	7705
700	27.56	684	26.93	17.07	37.64	7706
750	29.53	734	28.90	18.09	39.88	7707
800	31.50	784	30.87	19.22	42.38	7708
850	33.46	834	32.83	20.03	44.15	7709
900	35.43	884	34.80	21.37	47.12	7710
950	37.40	934	36.77	22.39	49.36	7711
1,000	39.37	984	38.74	23.41	51.61	7712
1,100	43.31	1,084	42.68	24.86	54.81	7713



Packing Unit – Sets per Box, all Lengths: 1

# FR 771A ECD

Easy Close Device Retrofit-Kit  
for Vertical Pantry Pull-Out Slide System FR 771A



## Specifications

-  synthetic material, steel
-  +5 °C to +40 °C  
+41 °F to +104 °F

## Characteristics

- Simple assembly due to plug-in system – the vertical pantry pull-out slide system FR 771A is already prepared for the installation of the Easy Close Device retrofit-kit.
- reliable, silent self closing device
- The easy close / self-closing and slam-resistant function is not compromised by varying load conditions.

## Delivery Set

- top slide:**
  - 1 x attachable damping system
- bottom slide:**
  - 1 x attachable damping system
  - assembly instruction

Designation

FR 771A ECD – Retrofit-kit for vertical pantry pull-out slide system FR 771A

Item No.

7749

Packing Unit – Set per Polybag: 1

# FR 777A ECD

Easy Close Device Retrofit-Kit  
for Vertical Pantry Pull-Out Slide System FR 777A

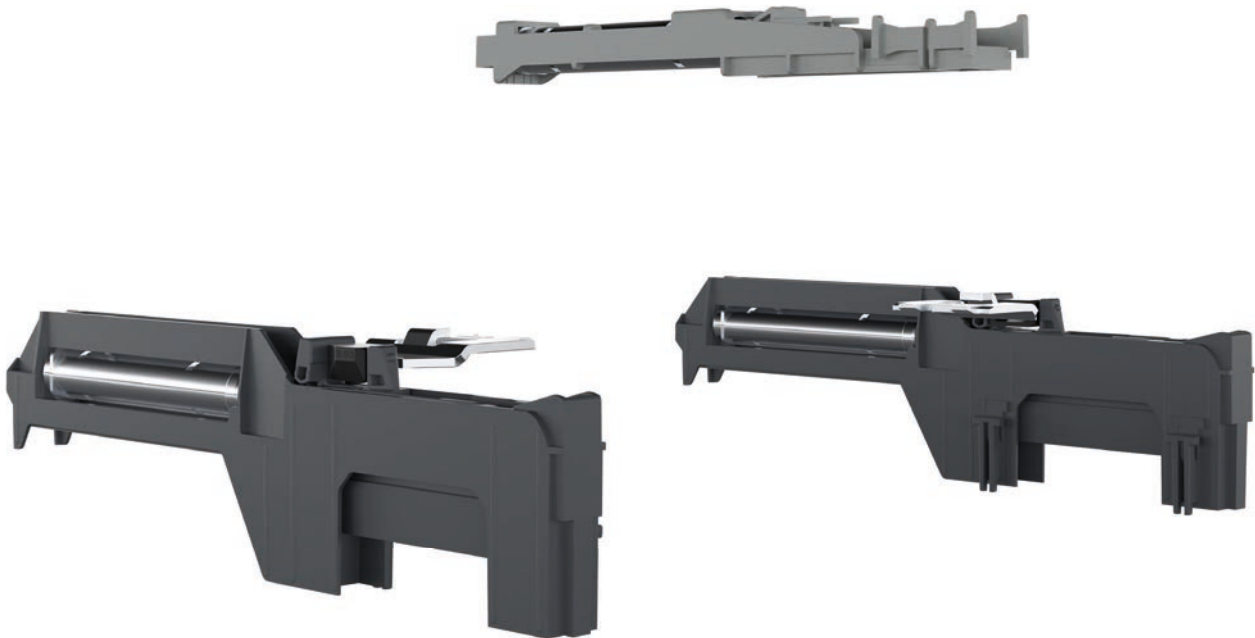

## Specifications

 synthetic material, steel

 +5 °C to +40 °C  
+41 °F to +104 °F

## Characteristics

- Simple assembly due to plug-in system – the vertical pantry pull-out slide system FR 777A is already prepared for the installation of the Easy Close Device retrofit-kit.
- reliable, silent self closing device
- The easy close / self-closing and slam-resistant function is not compromised by varying load conditions.

## Delivery Set

### top slide:

- 1 x attachable damping system

### bottom slide:

- 2 x attachable damping system
- 2 x follower, snap-on
- assembly instruction

Designation

FR 777A ECD – Retrofit-kit for vertical pantry pull-out slide system FR 777A

Item No.

7719

Packing Unit – Set per Polybag: 1



FULTERER **stainless steel roller bearing drawer slide systems** are used in many areas of daily lives, from **catering, refrigeration and professional kitchen equipment, clima-controlled medical cabinets** and **utility vehicle applications**. Its characteristics stand for corrosion-resistance, durability and robustness. Stainless steel in quality 1.4509, with rounded edges is utilized. Roller bearings are fabricated in stainless steel, quality 1.4034.

All stainless steel drawer slide systems are **NSF-tested** and meet the highest public health and safety standards. The NSF (National Sanitation Foundation) is an internationally recognized institution for the development and compliance with hygiene standards in the food-processing industry. The NSF-quality certificate is issued following inspection and the appropriate fulfillment of all NSF requirements.

FULTERER products feature **optional Easy Close Device (ECD) systems** for silent and linear self-closing, some of which can be retrofitted.

A grayscale photograph of a hand pulling a stainless steel roller bearing drawer slide system. The hand is positioned at the top right, with the thumb and index finger gripping the top edge of the drawer. The slide system is visible, showing the rollers and the track. The background is a plain, light-colored wall. A red semi-transparent rectangle is overlaid on the bottom half of the image, containing white text.

34 | 49

# STAINLESS STEEL ROLLER BEARING DRAWER SLIDE SYSTEMS





- REGULAR EXTENSION
- FULL EXTENSION
- ACCESSORIES

# FR 1051 SCC

Regular Extension Drawer Slide  
with Lateral Stability



## Specifications

-  side mount
-  15.0 mm / 0.59 in.
-  dynamic up to 50 kg / 110 lbs.
-  synthetic silent rollers
-  stainless steel 1.4509 / 441
-  -25 °C to +80 °C  
-13 °F to +176 °F

## Characteristics

- single-sided captive profile (right)
- rear backstop
- self-closing
- compatible with full extension drawer slide FR 6010 SCC
- available as heat-resistant version up to +210 °C (+410 °F)

## Dimensions

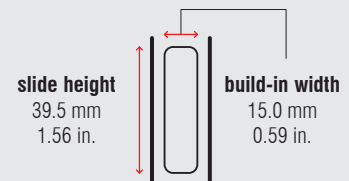

Length		Extension		Weight		Item No.
mm	inch	mm	inch	kg	lbs.	
400	15.75	294	11.57	0.95	2.09	1102
450	17.72	344	13.54	1.05	2.31	1103
500	19.69	394	15.51	1.20	2.63	1104
550	21.65	424	16.69	1.34	2.94	1105
600	23.62	474	18.66	1.43	3.15	1106
650	25.59	524	20.63	1.56	3.43	1107
700	27.56	574	22.60	*	*	1108
750	29.53	624	24.57	*	*	1109

Packing Unit – Sets per Box, all Lengths: 10

\* on request

# FR 1052 SCC

Regular Extension Drawer Slide  
with Lateral Stability



## Specifications

-  side mount
-  18.0 mm / 0.71 in.
-  dynamic up to 50 kg / 110 lbs.
-  synthetic silent rollers
-  stainless steel 1.4509 / 441
-  -25 °C to +80 °C  
-13 °F to +176 °F

## Characteristics

- single-sided captive profile (right)
- rear backstop
- self-closing
- compatible with full extension drawer slide FR 790 SCC and FR 785 SCC

## Dimensions

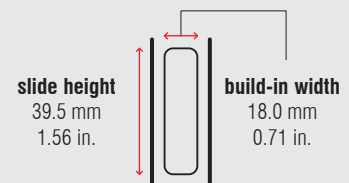

Length		Extension		Weight		Item No.
				per set		
mm	inch	mm	inch	kg	lbs.	
400	15.75	294	11.57	0.95	2.09	1601
450	17.72	344	13.54	1.07	2.37	1602
500	19.69	394	15.51	1.18	2.61	1603
550	21.65	424	16.69	1.30	2.87	1604
600	23.62	474	18.66	1.42	3.13	1605
650	25.59	524	20.63	1.52	3.35	1606
700	27.56	574	22.60	*	*	*
750	29.53	624	24.57	*	*	*

Packing Unit – Sets per Box, all Lengths: 10







\* on request

# FR 1052 SCC SC

Regular Extension Drawer Slide  
with Lateral Stability



## Specifications

-  side mount
-  18.0 mm / 0.71 in.
-  dynamic up to 50 kg / 110 lbs.
-  synthetic silent rollers
-  stainless steel 1.4509 / 441
-  -25 °C to +80 °C  
-13 °F to +176 °F

## Characteristics

- cabinet profile with bayonet mounting tabs and safety nose
- tool-less quick assembly of the cabinet profile
- single-sided captive profile (right)
- rear backstop
- self-closing
- compatible with full extension drawer slide FR 785 SCC SC

## Dimensions

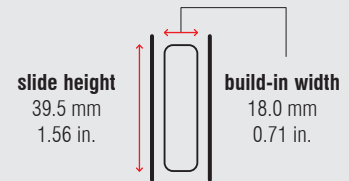

Length		Extension		Weight		Item No.
mm	inch	mm	inch	kg	lbs.	
400	15.75	294	11.57	0.96	2.11	<b>5302</b>
450	17.72	344	13.54	1.05	2.32	*
500	19.69	394	15.51	1.17	2.57	<b>5304</b>
550	21.65	424	16.69	1.29	2.84	*
600	23.62	474	18.66	1.40	3.10	<b>5306</b>
650	25.59	524	20.63	1.60	3.53	*
700	27.56	574	22.60	*	*	*
750	29.53	624	24.57	1.78	3.92	*

Packing Unit – Set per Box, all Lengths: 10

\* on request

# FR 2051 SCC

Regular Extension Drawer Slide  
with Lateral Stability



### Specifications

-  bottom mount
-  15.0 mm / 0.59 in.
-  dynamic up to 50 kg / 110 lbs.
-  synthetic silent rollers
-  stainless steel 1.4509 / 441
-  -25 °C to +80 °C  
-13 °F to +176 °F

### Characteristics

- single-sided captive profile (right)
- rear backstop
- self-closing
- available as heat-resistant version up to +210 °C (+410 °F)

### Dimensions

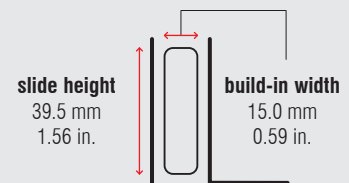

Length		Extension		Weight		Item No.
mm	inch	mm	inch	kg	lbs.	
400	15.75	294	11.57	1.13	2.49	1510
450	17.72	344	13.54	1.20	2.65	1511
500	19.69	394	15.51	1.31	2.89	1512
550	21.65	424	16.69	1.48	3.25	1513
600	23.62	474	18.66	1.61	3.54	1514
650	25.59	524	20.63	1.79	3.95	1515
700	27.56	574	22.60	1.87	4.13	1516
750	29.53	624	24.57	2.01	4.43	1517

Packing Unit – Sets per Box, all Lengths: 10





### Specifications

-  bottom mount
-  15.0 mm / 0.59 in.
-  dynamic up to 100 kg / 220 lbs.
-  stainless steel ball bearings with integrated synthetic gliding ring
-  stainless steel 1.4509 / 441
-  -25 °C to +80 °C  
-13 °F to +176 °F

### Characteristics

- rear backstop
- self-closing
- available as heat-resistant version up to +210 °C (+410 °F)

### Dimensions

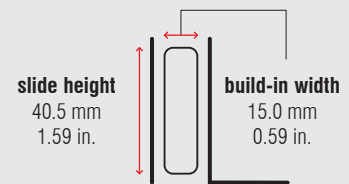

Length		Extension		Weight		Item No.
mm	inch	mm	inch	kg	lbs.	
400	15.75	294	11.57	1.94	4.28	1060
450	17.72	344	13.54	2.17	4.77	1061
500	19.69	394	15.51	2.41	5.31	1062
550	21.65	444	17.48	2.64	5.81	1063
600	23.62	494	19.45	2.89	6.37	1064
650	25.59	544	21.42	3.13	6.89	1065
700	27.56	584	22.99	3.36	7.40	1066
750	29.53	634	24.96	3.59	7.90	1067

Packing Unit – Sets per Box, all Lengths: 5

# FR 6010 SCC

Over Extension Telescopic Action Drawer Slide with Lateral Stability



## Specifications

-  side mount
-  15.0 mm / 0.59 in.
-  dynamic up to 50 kg / 110 lbs.
-  solid synthetic rollers, stainless steel ball bearings
-  stainless steel 1.4509 / 441
-  -25 °C to +80 °C  
-13 °F to +176 °F

## Characteristics

- high lateral stability
- middle profile with locking device for easy assembly
- dual-sided captive profile
- synthetic stop
- self-closing
- compatible with regular extension drawer slide FR 1051 SCC
- available as heat-resistant version up to +210 °C (+410 °F)

## Dimensions

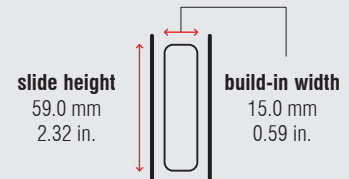

Length		Extension		Weight		Item No.	Item No.
				per set		solid synthetic rollers	heat-resistant
mm	inch	mm	inch	kg	lbs.		
300	11.81	320	12.60	1.41	3.11	90212	*
350	13.78	395	15.55	1.63	3.59	90213	2521
400	15.75	445	17.52	1.79	3.95	90214	2522
450	17.72	495	19.49	2.05	4.52	90215	*
500	19.69	545	21.46	2.28	5.02	90216	2524
550	21.65	595	23.43	2.50	5.50	90217	2525
600	23.62	645	25.39	2.71	5.97	90218	2526
650	25.59	695	27.36	2.94	6.48	90219	*
700	27.56	745	29.33	3.22	7.09	90220	*
750	29.53	795	31.30	3.43	7.56	90221	*

Packing Unit – Sets per Box, all Lengths: 6

\* on request



### Specifications

- side mount
- 18.0 mm / 0.71 in.
- dynamic up to 60 kg / 132 lbs. (full extension)  
dynamic up to 48 kg / 106 lbs. (over extension)
- solid synthetic rollers
- stainless steel 1.4509 / 441
- 25 °C to +80 °C  
-13 °F to +176 °F

### Characteristics

- high lateral stability
- cabinet and drawer profile with screw holes
- ideal running characteristic and smoothness of running through integrated progressive action
- integrated safety clip
- dual-sided captive profile
- synthetic stop
- self-closing
- compatible with regular extension drawer slide FR 1052 SCC
- Easy Close Device (ECD) can be ordered optionally

### Dimensions

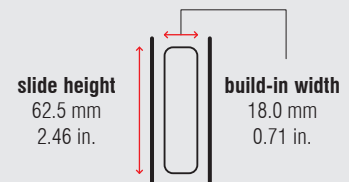

Length		Extension		Extension		Weight		Item No.	Item No.
		full extension		over extension		per set		full extension	over extension
mm	inch	mm	inch	mm	inch	kg	lbs.		
335	13.19	320	12.60	395	15.55	*	*	*	*
350	13.78	335	13.19	410	16.14	1.47	3.24	<b>8522</b>	*
385	15.16	370	14.57	445	17.52	*	*	*	*
400	15.75	385	15.16	460	18.11	1.68	3.70	<b>8524</b>	*
435	17.13	420	16.54	495	19.49	*	*	*	*
450	17.72	435	17.13	510	20.08	1.91	4.21	<b>8526</b>	*
485	19.09	470	18.50	545	21.46	*	*	*	*
500	19.69	485	19.09	560	22.05	2.14	4.72	<b>8528</b>	*
535	21.06	520	20.47	595	23.43	*	*	*	*
550	21.65	535	21.06	610	24.02	2.52	5.56	<b>8530</b>	*
585	23.03	570	22.44	645	25.39	*	*	*	*
600	23.62	585	23.03	660	25.98	2.60	5.73	<b>8532</b>	*
635	25.00	620	24.41	695	27.36	*	*	*	*
650	25.59	635	25.00	710	27.95	2.83	6.24	<b>8534</b>	*
685	26.97	670	26.38	745	29.33	*	*	*	*
700	27.56	685	26.97	760	29.92	3.05	6.72	<b>8536</b>	*
735	28.94	720	28.35	795	31.30	*	*	*	*
750	29.53	735	28.94	810	31.89	*	*	*	*

Packing Unit – Sets per Box, all Lengths: 5







\* on request

# FR 785 SCC SC

Full Extension Progressive Action Drawer Slide



## Specifications

-  side mount
-  18.0 mm / 0.71 in.
-  dynamic up to 60 kg / 132 lbs. (full extension)  
dynamic up to 48 kg / 106 lbs. (over extension)
-  solid synthetic rollers
-  stainless steel 1.4509 / 441
-  -25 °C to +80 °C  
-13 °F to +176 °F

## Characteristics

- high lateral stability
- cabinet profile with bayonet mounting tabs and safety nose
- drawer profile without screw holes
- tool-less quick assembly of the cabinet profile
- ideal running characteristic and smoothness of running through integrated progressive action
- integrated safety clip
- dual-sided captive profile
- synthetic stop
- self-closing

- compatible with regular extension drawer slide FR 1052 SCC SC
- Easy Close Device (ECD) can be ordered optionally

## Dimensions

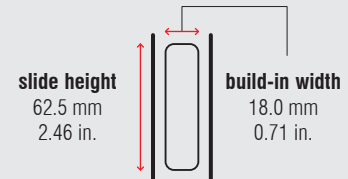

Length		Extension		Extension		Weight		Item No.	Item No.
		full extension		over extension		per set		full extension	over extension
mm	inch	mm	inch	mm	inch	kg	lbs.		
335	13.19	320	12.60	395	15.55	*	*	*	*
350	13.78	335	13.19	410	16.14	1.50	3.31	<b>8322</b>	*
385	15.16	370	14.57	445	17.52	*	*	*	*
400	15.75	385	15.16	460	18.11	1.71	3.77	<b>8324</b>	*
435	17.13	420	16.54	495	19.49	*	*	*	*
450	17.72	435	17.13	510	20.08	1.92	4.23	<b>8326</b>	*
485	19.09	470	18.50	545	21.46	*	*	*	*
500	19.69	485	19.09	560	22.05	2.13	4.70	<b>8328</b>	*
535	21.06	520	20.47	595	23.43	*	*	*	*
550	21.65	535	21.06	610	24.02	2.36	5.20	<b>8330</b>	*
585	23.03	570	22.44	645	25.39	*	*	*	*
600	23.62	585	23.03	660	25.98	2.60	5.73	<b>8332</b>	*
635	25.00	620	24.41	695	27.36	*	*	*	*
650	25.59	635	25.00	710	27.95	2.86	6.31	<b>8334</b>	*
685	26.97	670	26.38	745	29.33	*	*	*	*
700	27.56	685	26.97	760	29.92	*	*	*	*
735	28.94	720	28.35	795	31.30	*	*	*	*
750	29.53	735	28.94	810	31.89	*	*	*	*

Packing Unit – Sets per Box, all Lengths: 5





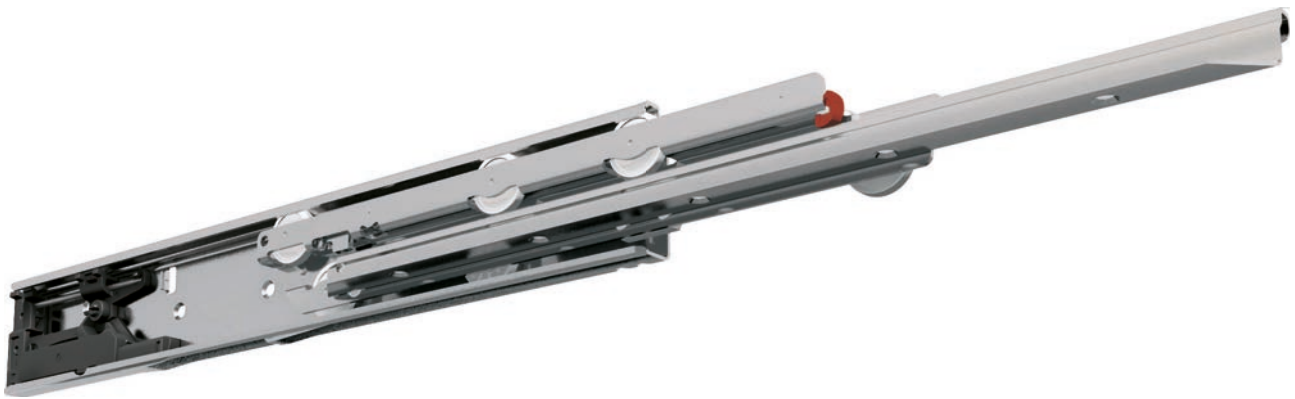

\* on request

# FR 786 SCC ECD

Full Extension Progressive Action Drawer Slide



## Specifications

-  bottom mount
-  18.0 mm / 0.71 in.
-  dynamic up to 60 kg / 132 lbs. (full extension)  
dynamic up to 48 kg / 106 lbs. (over extension)
-  solid synthetic rollers
-  stainless steel 1.4509 / 441
-  +5 °C to +40 °C  
+41 °F to +104 °F

## Characteristics

- high lateral stability
- cabinet and drawer profile with screw holes
- ideal running characteristic and smoothness of running through integrated progressive action
- integrated safety clip
- dual-sided captive profile
- Easy Close Device (ECD) pre-assembled

## Dimensions

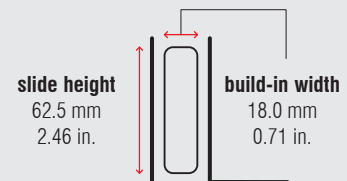

Length		Extension		Extension		Weight		Item No.	Item No.
		full extension		over extension		per set		full extension	over extension
mm	inch	mm	inch	mm	inch	kg	lbs.		
335	13.19	320	12.60	395	15.55	*	*	*	*
350	13.78	335	13.19	410	16.14	1.60	3.53	8222	*
385	15.16	370	14.57	445	17.52	*	*	*	*
400	15.75	385	15.16	460	18.11	1.86	4.10	8224	*
435	17.13	420	16.54	495	19.49	*	*	*	*
450	17.72	435	17.13	510	20.08	1.91	4.21	8226	*
485	19.09	470	18.50	545	21.46	*	*	*	*
500	19.69	485	19.09	560	22.05	2.33	5.14	8228	*
535	21.06	520	20.47	595	23.43	*	*	*	*
550	21.65	535	21.06	610	24.02	2.58	5.69	8230	*
585	23.03	570	22.44	645	25.39	*	*	*	*
600	23.62	585	23.03	660	25.98	2.80	6.17	8232	*
635	25.00	620	24.41	695	27.36	*	*	*	*
650	25.59	635	25.00	710	27.95	3.03	6.68	8234	*
685	26.97	670	26.38	745	29.33	*	*	*	*
700	27.56	685	26.97	760	29.92	3.28	7.23	8236	*
735	28.94	720	28.35	795	31.30	*	*	*	*
750	29.53	735	28.94	810	31.89	*	*	*	*

Packing Unit – Sets per Box, all Lengths: 5

\* on request



### Specifications

- side mount
- 18.0 mm / 0.71 in.
- dynamic up to 68 kg / 150 lbs. (full extension)  
dynamic up to 53 kg / 120 lbs. (over extension)
- solid synthetic rollers
- stainless steel 1.4509 / 441
- 25 °C to +80 °C  
-13 °F to +176 °F

### Characteristics

- high lateral stability
- cabinet and drawer profile with screw holes
- ideal running characteristic and smoothness of running through integrated progressive action
- integrated safety clip
- dual-sided captive profile
- synthetic stop
- self-closing
- compatible with regular extension drawer slide FR 1052 SCC
- available as heat-resistant version up to +110 °C (+230 °F) – load capacity 40 kg (90 lbs.) for over extension (drawer profile without screw holes)

### Dimensions

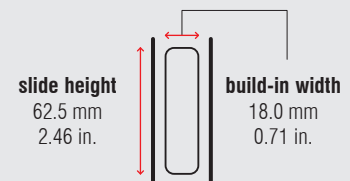

Length		Extension		Extension		Weight		Item No.	Item No.	Item No.
		full extension		over extension		per set		full extension	over extension	over extension heat-resistant
mm	inch	mm	inch	mm	inch	kg	lbs.			
350	13.78	335	13.19	410	16.14	1.62	3.57	7900	*	7970
400	15.75	385	15.16	460	18.11	1.81	3.99	7901	*	*
450	17.72	435	17.13	510	20.08	2.04	4.49	7902	*	7972
500	19.69	485	19.09	560	22.05	2.28	5.02	7903	*	7973
550	21.65	535	21.06	610	24.02	2.49	5.50	7904	7924	7974
600	23.62	585	23.03	660	25.98	2.73	6.01	7905	*	7975
650	25.59	635	25.00	710	27.95	2.98	6.57	7906	7926	*
700	27.56	685	26.97	760	29.92	3.18	7.00	7907	*	*
750	29.53	735	28.94	810	31.89	*	*	*	*	*

Packing Unit – Sets per Box, all Lengths: 5

\* on request









# FR 790 SCC SC

Full Extension Progressive Action Drawer Slide



## Specifications

-  side mount
-  18.0 mm / 0.71 in.
-  dynamic up to 68 kg / 150 lbs. (full extension)  
dynamic up to 53 kg / 120 lbs. (over extension)
-  solid synthetic rollers
-  stainless steel 1.4509 / 441
-  -25 °C to +80 °C  
-13 °F to +176 °F

## Characteristics

- high lateral stability
- cabinet profile with bayonet mounting tabs and safety nose
- drawer profile without screw holes
- tool-less quick assembly of the cabinet profile
- ideal running characteristic and smoothness of running through integrated progressive action
- integrated safety clip
- dual-sided captive profile
- synthetic stop
- self-closing
- compatible with regular extension drawer slide FR 1052 SCC SC

## Dimensions

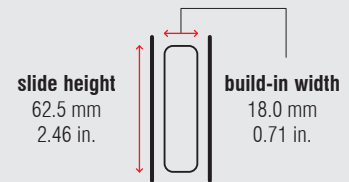







Length		Extension		Extension		Weight		Item No.	Item No.
		full extension		over extension		per set		full extension	over extension
mm	inch	mm	inch	mm	inch	kg	lbs.		
350	13.78	335	13.19	410	16.14	1.60	3.52	*	<b>8020</b>
400	15.75	385	15.16	460	18.11	1.81	3.99	*	<b>8021</b>
450	17.72	435	17.13	510	20.08	2.04	4.49	*	<b>8022</b>
500	19.69	485	19.09	560	22.05	2.27	5.00	*	<b>8023</b>
550	21.65	535	21.06	610	24.02	2.50	5.50	*	<b>8024</b>
600	23.62	585	23.03	660	25.98	2.77	6.10	*	<b>8025</b>
650	25.59	635	25.00	710	27.95	2.98	6.56	*	<b>8026</b>
700	27.56	685	26.97	760	29.92	3.21	7.08	*	<b>8027</b>
750	29.53	735	28.94	810	31.89	*	*	*	*

Packing Unit – Sets per Box, all Lengths: 5

\* on request



### Specifications

-  bottom mount
-  18.0 mm / 0.71 in.
-  dynamic up to 68 kg / 150 lbs. (full extension)  
dynamic up to 53 kg / 120 lbs. (over extension)
-  solid synthetic rollers
-  stainless steel 1.4509 / 441
-  -25 °C to +80 °C  
-13 °F to +176 °F

### Characteristics

- high lateral stability
- cabinet and drawer profile with screw holes
- ideal running characteristic and smoothness of running through integrated progressive action
- integrated safety clip
- dual-sided captive profile
- synthetic stop
- self-closing

### Dimensions

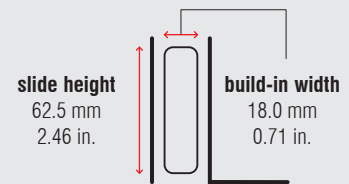

Length		Extension		Extension		Weight		Item No.	Item No.
		full extension		over extension		per set		full extension	over extension
mm	inch	mm	inch	mm	inch	kg	lbs.		
350	13.78	335	13.19	410	16.14	*	*	*	*
400	15.75	385	15.16	460	18.11	1.95	4.29	<b>7941</b>	*
450	17.72	435	17.13	510	20.08	2.21	4.87	<b>7942</b>	*
500	19.69	485	19.09	560	22.05	2.46	5.43	<b>7943</b>	*
550	21.65	535	21.06	610	24.02	2.72	6.00	<b>7944</b>	<b>81413</b>
600	23.62	585	23.03	660	25.98	2.94	6.48	<b>7945</b>	*
650	25.59	635	25.00	710	27.95	3.17	6.99	<b>7946</b>	*
700	27.56	685	26.97	760	29.92	3.41	7.52	<b>7947</b>	*
750	29.53	735	28.94	810	31.89	*	*	*	*

Packing Unit – Sets per Box, all Lengths: 5

\* on request



### Specifications

- bottom mount
- 24.0 mm / 0.95 in.
- dynamic up to 120 kg / 265 lbs. (full extension)  
dynamic up to 105 kg / 231 lbs. (over extension)  
dynamic up to 90 kg / 198 lbs. (heat-resistant)
- solid synthetic rollers
- stainless steel 1.4509 / 441
- 25 °C to +80 °C  
-13 °F to +176 °F

### Characteristics

- high lateral stability
- cabinet profile with screw holes and drawer profile without holes
- ideal running characteristic and smoothness of running through integrated progressive action
- integrated safety clip
- dual-sided captive profile
- self-closing
- available as heat-resistant version up to +110 °C (+230 °F) – load capacity for full extension 90 kg (198 lbs.)

### Dimensions

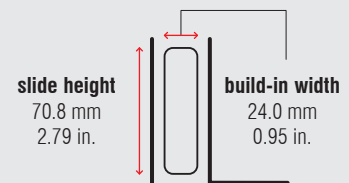







Length		Extension		Extension		Weight		Item No.	Item No.	Item No.
		full extension		over extension		per set		full extension	full extension heat-resistant	over extension
mm	inch	mm	inch	mm	inch	kg	lbs.			
400	15.75	385	15.16	460	18.11	3.51	7.74	7130	7140	*
450	17.72	435	17.13	510	20.08	4.00	8.82	7131	*	*
500	19.69	485	19.09	560	22.05	4.44	9.79	7132	7142	*
550	21.65	535	21.06	610	24.02	4.86	10.72	7133	7143	*
600	23.62	585	23.03	660	25.98	5.28	11.63	7134	7144	*
650	25.59	635	25.00	710	27.95	5.77	12.72	7135	7145	*
700	27.56	685	26.97	760	29.92	6.37	14.04	7136	*	82561
750	29.53	735	28.94	810	31.89	7.00	15.43	7137	*	*

Packing Unit – Sets per Box: from 400 to 600 mm: 4 | from 650 to 750 mm: 2

\* on request



### Specifications

-  side mount
-  24.0 mm / 0.95 in.
-  dynamic up to 120 kg / 265 lbs. (full extension)  
dynamic up to 105 kg / 231 lbs. (over extension)
-  solid synthetic rollers
-  stainless steel 1.4509 / 441
-  -25 °C to +80 °C  
-13 °F to +176 °F

### Characteristics

- high lateral stability
- cabinet profile with screw holes and drawer profile without holes
- ideal running characteristic and smoothness of running through integrated progressive action
- integrated safety clip
- dual-sided captive profile
- self-closing
- available as heat-resistant version up to +110 °C (+230 °F) – load capacity for full extension 90 kg (198 lbs.), 80 kg (176 lbs.) for over extension

### Dimensions

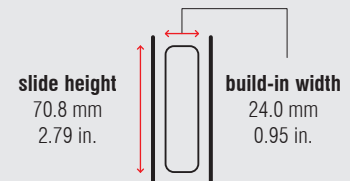

Length		Extension		Extension		Weight		Item No.	Item No.
		full extension		over extension		per set		full extension	over extension
mm	inch	mm	inch	mm	inch	kg	lbs.		
400	15.75	385	15.16	460	18.11	3.50	7.71	<b>7110</b>	*
450	17.72	435	17.13	510	20.08	3.98	8.76	<b>7111</b>	*
500	19.69	485	19.09	560	22.05	4.42	9.73	<b>7112</b>	<b>7122</b>
550	21.65	535	21.06	610	24.02	4.84	10.67	<b>7113</b>	<b>7123</b>
600	23.62	585	23.03	660	25.98	5.30	11.67	<b>7114</b>	<b>7124</b>
650	25.59	635	25.00	710	27.95	5.76	12.69	<b>7115</b>	*
700	27.56	685	26.97	760	29.92	6.20	13.67	<b>7116</b>	*
750	29.53	735	28.94	810	31.89	6.63	14.62	<b>7117</b>	*

Packing Unit – Sets per Box: from 400 to 600 mm: **4** | from 650 to 750 mm: **2**

\* on request

# Easy Close Device

Retrofit-Kit  
for FR 793 SCC / FR 794 SCC / FR 795 SCC / FR 796 SCC



## ECD 79

### Temperature range

-+40 °C to -25 °C  
+104 °F to -13 °F

Designation	Weight		Item No.
	kg	lbs.	
ECD 79	*	*	70901

Packing Unit – Set per Polybag: 1

\* on request

# FR 712 CNS | Locking System

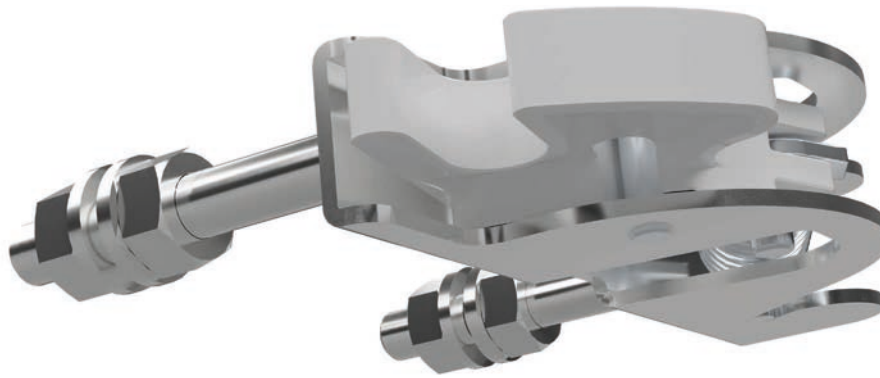

## Specifications

 stainless steel 1.4301 / 304

## Characteristics

- positive locking device with compression spring
- retention function via compression spring
- mounting via 2 threaded bolts
- supplied without catch pin

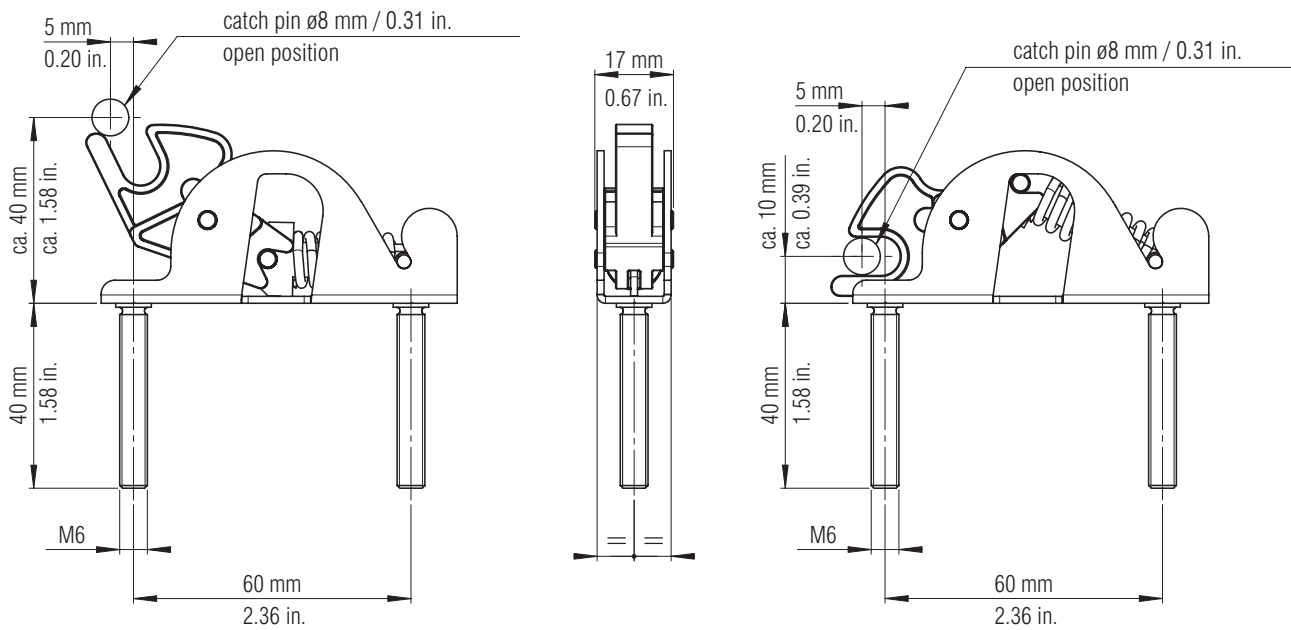

Designation

Locking System

Item No.

6100067

Packing Unit – Piece: 1

**Ball bearing drawer slides** enable the drawer to be pulled out completely, in the version of **over extension**, even up to the front edge of the cabinet.

**Product features:**

- high dynamic load capacity from 25 to 500 kg / 55 to 1,102 lbs.
- nominal lengths from 150 to 1,500 mm / 5.91 to 59.06 in.
- galvanised steel, stainless steel or aluminium versions

For individual customer requirements customized specific designs with adapted fastening variants are available for almost unlimited type of applications.





52 | 68

# **BALL BEARING DRAWER SLIDES**

- REGULAR EXTENSION
- FULL EXTENSION
- ACCESSORIES

# FR 5000 | Full Extension Ball Bearing Slide



## Specifications

-  side mount
-  13.0 mm / 0.51 in.
-  dynamic up to 45 kg / 100 lbs.
-  ball bearing cages
-  steel, zinc plated

## Characteristics

- pitch 32 mm (1.26 in.) compatible hole locations
- drawer profile with disconnect release trigger
- tolerance absorbing mounting tabs

## Dimensions

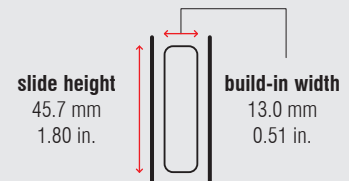

Length		Extension		Weight		Item No.
				per set		zinc plated
mm	inch	mm	inch	kg	lbs.	
250	9.84	250	9.84	0.73	1.60	5050
300	11.81	302	11.89	0.89	1.96	5051
350	13.78	354	13.94	1.07	2.36	5052
400	15.75	400	15.75	1.17	2.58	5053
450	17.72	452	17.80	1.35	2.97	5054
500	19.69	515	20.28	1.53	3.36	5055
550	21.65	558	21.97	1.68	3.69	5056
600	23.62	600	23.62	1.83	4.02	5057
650	25.59	650	25.59	1.98	4.35	5058
700	27.56	705	27.76	2.14	4.71	5059







Packing Unit – Sets per Box, all Lengths: 10

# FR 5001 ECD

Full Extension Ball Bearing Slide



## Specifications

-  side mount
-  12.8 mm / 0.50 in.
-  dynamic up to 45 kg / 100 lbs.
-  ball bearing cages
-  steel, zinc plated
-  +5 °C to +40 °C  
+41 °F to +104 °F

## Characteristics

- pitch 32 mm (1.26 in.) compatible hole locations
- drawer profile with disconnect release trigger
- tolerance absorbing mounting tabs

## Dimensions

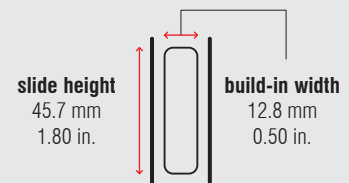





Length		Extension		Weight		Item No.
				per set		zinc plated
mm	inch	mm	inch	kg	lbs.	
300	11.81	245	9.65	0.90	1.98	5061
355	13.98	350	13.78	1.05	2.32	5062
405	15.95	400	15.75	1.20	2.65	5063
450	17.72	450	17.72	1.36	3.00	5064
500	19.69	500	19.69	1.51	3.33	5065
550	21.65	550	21.65	1.61	3.55	5066
600	23.62	600	23.62	1.81	3.99	5067
650	25.59	650	25.59	1.97	4.34	5068
700	27.56	700	27.56	2.13	4.70	5069

Packing Unit – Sets per Box, all Lengths: 10

# FR 5002 CNS | Full Extension Ball Bearing Slide



## Specifications

-  side mount
-  13.1 mm / 0.52 in.
-  dynamic up to 45 kg / 100 lbs.
-  stainless steel ball bearing cages
-  stainless steel 1.4301 / 304

## Characteristics

- pitch 32 mm (1.26 in.) compatible hole locations
- drawer profile with disconnect release trigger
- tolerance absorbing mounting tabs

## Dimensions

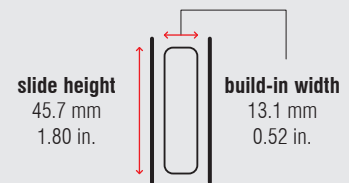

Length		Extension		Weight		Item No.
				per set		stainless steel
mm	inch	mm	inch	kg	lbs.	
250	9.84	250	9.84	*	*	*
300	11.81	300	11.81	*	*	*
350	13.78	350	13.78	*	*	*
400	15.75	400	15.75	1.18	2.60	5113
450	17.72	450	17.72	1.32	2.91	5114
500	19.69	500	19.69	1.50	3.31	5115
550	21.65	550	21.65	1.65	3.64	5116
600	23.62	600	23.62	1.80	3.97	5117
650	25.59	650	25.59	*	*	*
700	27.56	700	27.56	*	*	*
750	29.53	750	29.53	*	*	*

Packing Unit – Sets per Box, all Lengths: 10

\* on request

# FR 5036 | Full Extension Ball Bearing Slide



## Specifications

-  side mount
-  13.0 mm / 0.51 in.
-  dynamic up to 30 kg / 66 lbs.
-  ball bearing cages
-  steel, zinc plated

## Characteristics

- pitch 32 mm (1.26 in.) compatible hole locations
- drawer profile with disconnect release trigger
- tolerance absorbing mounting tabs
- self-closing mechanism

## Dimensions

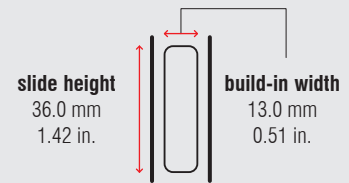

Length		Extension		Weight		Item No.
				per set		zinc plated
mm	inch	mm	inch	kg	lbs.	
250	9.84	254	10.00	0.58	1.28	5080
300	11.81	305	12.01	0.69	1.52	5081
350	13.78	356	14.02	0.82	1.81	5082
400	15.75	406	15.99	0.92	2.03	5083
450	17.72	457	17.99	1.06	2.34	5084
500	19.69	508	20.00	1.15	2.54	5085
550	21.65	559	22.01	1.27	2.80	5086
600	23.62	610	24.02	1.39	3.06	5087

Packing Unit – Sets per Box, all Lengths: 20

# FR 5052 | Full Extension Ball Bearing Slide



## Specifications

-  side mount
-  13.0 mm / 0.51 in.
-  dynamic up to 90 kg / 198 lbs.
-  ball bearing cages
-  steel, zinc plated

## Characteristics

- pitch 32 mm (1.26 in.) compatible hole locations
- drawer profile with disconnect release trigger

## Dimensions

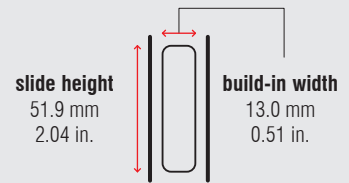



Length		Extension		Weight		Item No.
				per set		zinc plated
mm	inch	mm	inch	kg	lbs.	
300	11.81	300	11.81	1.37	3.02	5151
350	13.78	350	13.78	1.59	3.51	5152
400	15.75	400	15.75	1.83	4.03	5153
450	17.72	450	17.72	2.05	4.52	5154
500	19.69	500	19.69	2.33	5.13	5155
550	21.65	550	21.65	2.69	5.92	5156
600	23.62	600	23.62	2.80	6.17	5157
650	25.59	650	25.59	3.05	6.72	5158
700	27.56	700	27.56	3.30	7.28	5159

Packing Unit – Sets per Box: from 300 to 450 mm: **10** | from 500 to 550 mm: **8** | from 600 to 700 mm: **6**

# FR 5400 | Full Extension Ball Bearing Slide



## Specifications

-  side mount
-  19.5 mm / 0.77 in.
-  dynamic up to 250 kg / 550 lbs.
-  stainless steel ball bearing cages
-  steel, zinc plated

## Characteristics

- symmetrical design – can therefore be used on both sides
- slides are non-detachable
- applicable for flat-mount installation – reduced load capacity

## Dimensions

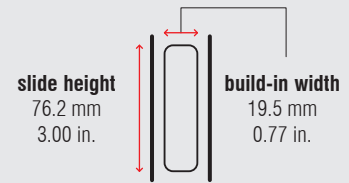

Length		Extension		Weight		Item No.
				per set		zinc plated
mm	inch	mm	inch	kg	lbs.	
203.2	8	203.2	8	1.95	4.30	5500
254.0	10	254.0	10	2.45	5.40	5501
304.8	12	304.8	12	2.98	6.56	5502
355.6	14	355.6	14	3.48	7.66	5503
406.4	16	406.4	16	4.00	8.82	5504
457.2	18	457.2	18	4.70	10.36	5505
508.0	20	508.0	20	5.20	11.46	5506
558.8	22	558.8	22	5.55	12.24	5507
609.6	24	609.6	24	6.05	13.34	5508
660.4	26	660.4	26	6.60	14.55	5509
711.2	28	711.2	28	7.10	15.65	5510
762.0	30	762.0	30	7.55	16.64	5511
812.8	32	812.8	32	8.10	17.86	5512
863.3	34	863.3	34	8.60	18.96	5513
914.4	36	914.4	36	9.10	20.06	5514
965.2	38	965.2	38	9.60	21.16	5515
1,016.0	40	1,016.0	40	10.30	22.71	5516
1,066.8	42	1,066.8	42	11.00	24.25	5517
1,117.6	44	1,117.6	44	11.40	25.13	5518
1,168.4	46	1,168.4	46	11.80	26.01	5519
1,219.2	48	1,219.2	48	12.30	27.12	5520
1,270.0	50	1,270.0	50	12.70	28.00	5521
1,320.0	52	1,320.0	52	13.20	29.10	5522
1,371.6	54	1,371.6	54	13.60	29.98	5523
1,422.4	56	1,422.4	56	14.10	31.09	5524
1,473.2	58	1,473.2	58	14.60	32.19	5525
1,524.0	60	1,524.0	60	15.40	33.95	5526

Packing Unit – Sets per Box: from 203.2 to 609.6 mm: 4 | from 660.4 to 863.3 mm: 2 | from 914.4 to 1,524.0 mm: 1



# FR 5400L

Full Extension Ball Bearing Slide  
with Locking Mechanism



## Specifications

-  side mount
-  19.5 mm / 0.77 in.
-  dynamic up to 250 kg / 550 lbs.
-  stainless steel ball bearing cages
-  steel, zinc plated

## Characteristics

- lock-in and lock-out mechanism
- not symmetrical – function of the locking lever
- slides are non-detachable

## Dimensions

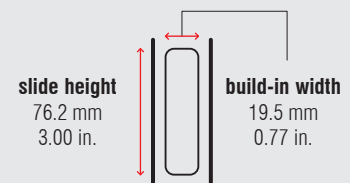

Length		Extension		Weight		Item No.
				per set		zinc plated
mm	inch	mm	inch	kg	lbs.	
304.8	12	304.8	12	3.21	7.08	<b>5602</b>
355.6	14	355.6	14	3.75	8.27	<b>5603</b>
406.4	16	406.4	16	4.27	9.41	<b>5604</b>
457.2	18	457.2	18	4.82	10.63	<b>5605</b>
508.0	20	508.0	20	5.35	11.79	<b>5606</b>
558.8	22	558.8	22	5.85	12.90	<b>5607</b>
609.6	24	609.6	24	6.32	13.93	<b>5608</b>
660.4	26	660.4	26	7.00	15.43	<b>5609</b>
711.2	28	711.2	28	7.45	16.42	<b>5610</b>
762.0	30	762.0	30	7.95	17.53	<b>5611</b>
812.8	32	812.8	32	8.50	18.74	<b>5612</b>
863.6	34	863.6	34	9.00	19.84	<b>5613</b>
914.4	36	914.4	36	9.50	20.94	<b>5614</b>
965.2	38	965.2	38	10.00	22.05	<b>5615</b>
1,016.0	40	1,016.0	40	10.70	23.59	<b>5616</b>
1,066.8	42	1,066.8	42	11.40	25.13	<b>5617</b>
1,117.6	44	1,117.6	44	11.80	26.01	<b>5618</b>
1,168.4	46	1,168.4	46	12.30	27.12	<b>5619</b>
1,219.2	48	1,219.2	48	12.70	28.00	<b>5620</b>
1,270.0	50	1,270.0	50	13.10	28.88	<b>5621</b>
1,320.8	52	1,320.8	52	13.80	30.42	<b>5622</b>
1,371.6	54	1,371.6	54	14.10	31.09	<b>5623</b>
1,422.4	56	1,422.4	56	14.50	31.97	<b>5624</b>
1,473.2	58	1,473.2	58	15.00	33.07	<b>5625</b>
1,524.0	60	1,524.0	60	15.80	34.83	<b>5626</b>

Packing Unit – Sets per Box: from 304.8 to 609.6 mm: **4** | from 660.4 to 863.6 mm: **2** | from 914.4 to 1,524.0 mm: **1**

# FR 5426 OE | Over Extension Ball Bearing Slide



## Specifications

-  side mount
-  26.0 mm / 1.02 in.
-  dynamic up to 350 kg / 770 lbs.
-  stainless steel ball bearing cages
-  steel, zinc plated

## Characteristics

- symmetrical design
- slides are non-detachable
- applicable for flat-mount installation – reduced load capacity
- over extension of 25 mm (0.98 in.)

## Dimensions

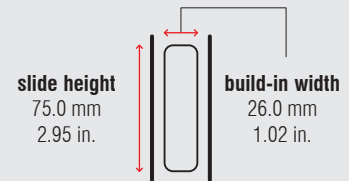





Length		Extension		Weight		Item No.
				per set		zinc plated
mm	inch	mm	inch	kg	lbs.	
300	11.81	310	12.20	5.35	11.79	5561
350	13.78	360	14.17	6.20	13.67	5562
400	15.75	410	16.14	7.10	15.65	5563
450	17.72	460	18.11	7.55	16.64	5564
500	19.69	510	20.08	8.45	18.63	5565
550	21.65	560	22.05	9.35	20.61	5566
600	23.62	610	24.02	10.80	23.81	5567
650	25.59	660	25.98	11.10	24.47	5568
700	27.56	710	27.95	12.00	26.46	5569
750	29.53	760	29.92	12.90	28.44	5570
800	31.50	810	31.89	13.80	30.42	5571
850	33.46	860	33.86	14.70	32.41	5572
900	35.43	910	35.83	15.60	34.39	5573
950	37.40	960	37.80	16.50	36.38	5574
1,000	39.37	1,010	39.76	17.40	38.36	5575

Packing Unit – Sets per Box: from 300 to 550 mm: 2 | from 600 to 1,000 mm: 1

# FR 5432 OE | Over Extension Ball Bearing Slide



## Specifications

-  side mount
-  32.0 mm / 1.26 in.
-  dynamic up to 220 kg / 485 lbs.
-  stainless steel ball bearing cages
-  steel, zinc plated

## Characteristics

- 50 % over extension
- symmetrical design
- slides are non-detachable
- applicable for flat-mount installation – reduced load capacity

## Dimensions

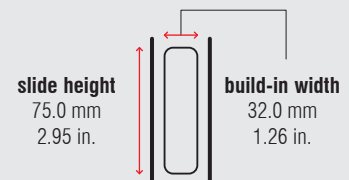





Length		Extension		Weight		Item No.
				per set		zinc plated
mm	inch	mm	inch	kg	lbs.	
300	11.81	450	17.72	5.49	12.10	5581
350	13.78	525	20.67	6.45	14.22	5582
400	15.75	600	23.62	7.45	16.42	5583
450	17.72	675	26.57	8.55	18.85	5584
500	19.69	750	29.53	9.50	20.94	5585
550	21.65	825	32.48	10.50	23.15	5586
600	23.62	900	35.43	11.40	25.13	5587
650	25.59	975	38.39	12.50	27.56	5588
700	27.56	1,050	41.34	13.40	29.54	5589
750	29.53	1,125	44.29	14.50	31.97	5590
800	31.50	1,200	47.24	15.40	33.95	5591
850	33.46	1,275	50.20	16.40	36.16	5592
900	35.43	1,350	53.15	17.30	38.14	5593
950	37.40	1,425	56.10	18.30	40.34	5594
1,000	39.37	1,500	59.06	19.30	42.55	5595

Packing Unit – Sets per Box: from 300 to 550 mm: 2 | from 600 to 1,000 mm: 1

# FR 5439 | Full Extension Ball Bearing Slide



## Specifications

-  side mount
-  39.0 mm / 1.54 in.
-  dynamic up to 500 kg / 1,100 lbs.
-  stainless steel ball bearing cages
-  steel, zinc plated

## Characteristics

- ball bearing slide for highest load capacities
- symmetrical design
- slides are non-detachable
- applicable for flat-mount installation – reduced load capacity
- synthetic stops

## Dimensions

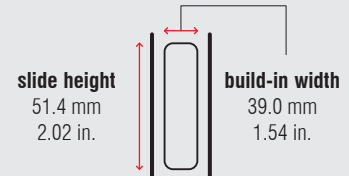

Length		Extension		Weight		Item No.
				per set		zinc plated
mm	inch	mm	inch	kg	lbs.	
400	15.75	400	15.75	8.80	19.40	<b>5643</b>
450	17.72	450	17.72	10.00	22.05	<b>5644</b>
500	19.69	500	19.69	11.20	24.69	<b>5645</b>
550	21.65	550	21.65	12.40	27.34	<b>5646</b>
600	23.62	600	23.62	13.60	29.98	<b>5647</b>
650	25.59	650	25.59	14.80	32.63	<b>5648</b>
700	27.56	700	27.56	16.00	35.27	<b>5649</b>
750	29.53	750	29.53	17.20	37.92	<b>5650</b>
800	31.50	800	31.50	18.40	40.57	<b>5651</b>
850	33.46	850	33.46	19.60	43.21	<b>5652</b>
900	35.43	900	35.43	20.80	45.86	<b>5653</b>
950	37.40	950	37.40	22.00	48.50	<b>5654</b>
1,000	39.37	1,000	39.37	23.30	51.37	<b>5655</b>

Packing Unit – Sets per Box, all Lengths: 1

# FR 5609 | Full Extension Ball Bearing Slide



## Specifications

-  side mount
-  19.1 mm / 0.75 in.
-  dynamic up to 100 kg / 220 lbs.
-  stainless steel ball bearing cages
-  steel, zinc plated

## Characteristics

- drawer profile with disconnect release trigger
- symmetrical design
- with hold close detent
- from length 304.8 mm (12 in.) to length 711.2 mm (28 in.) with standard over extension of 25 mm (0.98 in.)

## Dimensions

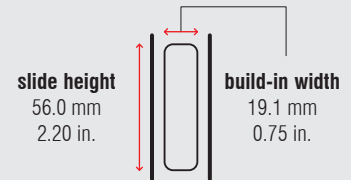







Length		Extension		Weight		Item No.
				per set		zinc plated
mm	inch	mm	inch	kg	lbs.	
254.0	10	254.0	10	1.46	3.22	5002
304.8	12	330.2	13	1.75	3.86	5003
355.6	14	381.0	15	2.04	4.50	5004
406.4	16	431.8	17	2.36	5.20	5005
457.2	18	482.6	19	2.68	5.91	5006
508.0	20	533.4	21	3.00	6.61	5007
558.8	22	584.2	23	3.46	7.63	5008
609.6	24	635.0	25	3.64	8.02	5009
660.4	26	685.8	27	4.08	8.99	5010
711.2	28	736.6	29	4.24	9.35	5011
762.0	30	762.0	30	4.53	9.99	5012
812.8	32	812.8	32	4.84	10.67	5013
863.6	34	863.6	34	5.14	11.33	5014
914.4	36	914.4	36	5.44	11.99	5015
965.2	38	965.2	38	5.75	12.68	5016
1,016.0	40	1,016.0	40	6.07	13.38	5017
1,066.8	42	1,066.8	42	6.36	14.02	5018
1,117.6	44	1,117.6	44	6.67	14.70	5019

Packing Unit – Sets per Box: from 254.0 to 457.2 mm: **8** | from 508.0 to 711.2 mm: **6** | from 762.0 to 1,117.6 mm: **4**



### Specifications

-  side mount
-  19.1 mm / 0.75 in.
-  dynamic up to 80 kg / 176 lbs.
-  ball bearing cages
-  steel, zinc plated
-  +5 °C to +40 °C  
+41 °F to +104 °F

### Characteristics

- drawer profile with disconnect release trigger
- symmetrical design

### Dimensions

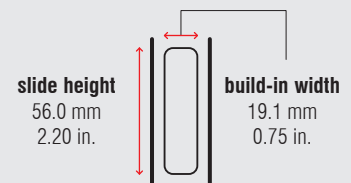

Length		Extension		Weight		Item No.
				per set		zinc plated
mm	inch	mm	inch	kg	lbs.	
355.6	14	355.6	14	*	*	<b>5919</b>
406.4	16	406.4	16	*	*	<b>5920</b>
457.2	18	457.2	18	*	*	<b>5921</b>
508.0	20	508.0	20	*	*	<b>5922</b>
558.8	22	558.8	22	*	*	<b>5923</b>
609.6	24	609.6	24	*	*	<b>5924</b>
660.4	26	660.4	26	*	*	<b>5925</b>
711.2	28	711.2	28	*	*	<b>5926</b>
762.0	30	762.0	30	*	*	<b>5927</b>

Packing Unit – Sets per Box: from 355.6 to 457.2 mm: **8** | from 508.0 to 609.6 mm: **6** | from 660.4 to 762.0 mm: **4**





\* on request

# FR 5826

## Full Extension Aluminium Ball Bearing Slide



### Specifications

-  side mount
-  26.0 mm / 1.02 in.
-  dynamic up to 300 kg / 660 lbs.
-  stainless steel ball bearing cages
-  aluminium

### Characteristics

- lightweight ball bearing slide with high weight capacity
- symmetrical design
- slides are non-detachable
- applicable for flat-mount installation – reduced load capacity

### Dimensions

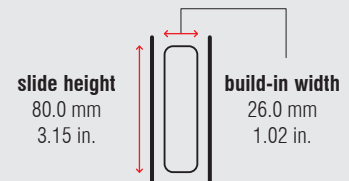

Length		Extension		Weight		Item No.
				per set		aluminium
mm	inch	mm	inch	kg	lbs.	
300	11.81	300	11.81	2.41	5.31	5661
350	13.78	350	13.78	2.85	6.28	5662
400	15.75	400	15.75	3.31	7.30	5663
450	17.72	450	17.72	3.76	8.29	5664
500	19.69	500	19.69	4.20	9.26	5665
550	21.65	550	21.65	4.63	10.21	5666
600	23.62	600	23.62	5.04	11.12	5667
650	25.59	650	25.59	5.51	12.15	5668
700	27.56	700	27.56	5.86	12.92	5669
750	29.53	750	29.53	6.25	13.78	5670
800	31.50	800	31.50	6.72	14.82	5671
850	33.46	850	33.46	7.22	15.92	5672
900	35.43	900	35.43	7.65	16.87	5673
950	37.40	950	37.40	7.95	17.53	5674
1,000	39.37	1,000	39.37	8.50	18.74	5675

Packing Unit – Sets per Box: from 300 to 750 mm: 3 | from 800 to 1,000 mm: 2



# FR 5328

## Two-Way Regular Extension Ball Bearing Slide



### Specifications

-  side mount
-  13.0 mm / 0.51 in.
-  dynamic up to 400 kg / 882 lbs.
-  stainless steel ball bearing cages
-  steel, zinc plated

### Characteristics

- two-way regular extension – allows to be operated to both sides with end stop
- symmetrical design
- slides are non-detachable
- applicable for flat-mount installation – reduced load capacity

### Dimensions

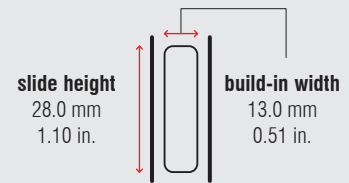

Length		Extension		Weight		Item No.
				per set		zinc plated
mm	inch	mm	inch	kg	lbs.	
130	5.12	74	2.91	0.54	1.19	5541
210	8.27	116	4.57	0.90	1.98	5542
290	11.42	148	5.83	1.26	2.78	5543
370	14.57	190	7.48	1.60	3.53	5544
450	17.72	232	9.13	1.96	4.32	5545
530	20.87	274	10.79	2.32	5.11	5546
610	24.02	316	12.44	2.62	5.78	5547
690	27.17	358	14.09	2.96	6.53	5548
770	30.31	400	15.75	3.30	7.28	5549
850	33.46	433	17.05	3.66	8.07	5550
930	36.61	475	18.70	4.00	8.82	5551
1,010	39.76	517	20.35	4.34	9.57	5552
1,090	42.91	559	22.01	4.70	10.36	5553
1,170	46.06	601	23.66	5.04	11.11	5554

Packing Unit – Sets per Box, all Lengths: 5

# FR 5000 ASW | Side Mount Bracket for FR 5000

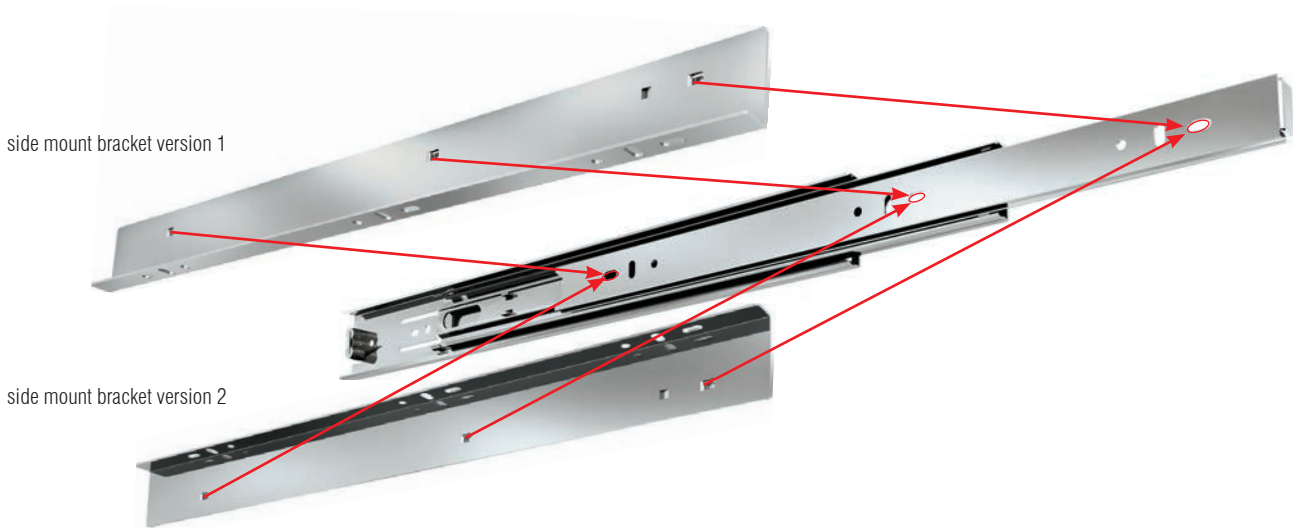

## Specifications

-  side mount
-  14.0 mm / 0.55 in.
-  steel, zinc plated

## Characteristics

- special side mount bracket for lateral mounting on FR 5000
- for various mounting versions:
  - floor mounting
  - tray mounting
  - bottom mount drawer mounting

Length mount bracket		Length Slide		Weight		Item No.
				per set		zinc plated
mm	inch	mm	inch	kg	lbs.	
400	15.75	400	15.75	0.36	0.80	5032
450	17.72	452	17.80	0.41	0.91	5033
500	19.69	515	20.28	0.46	1.02	5043
550	21.65	558	21.97	0.51	1.13	5035

Packing Unit – Sets per Box, all Lengths: 30

# FR 5400 ASW

## Side Mount Brackets for Full Extension Ball Bearing Slides FR 5400 and FR 5400L



### Specifications

-  side mount
-  250 kg / 550 lbs.
-  steel, zinc plated

### Characteristics

- special side mount bracket for lateral mounting on FR 5400 and FR 5400L
- for various mounting versions:
  - floor mounting
  - tray mounting
  - bottom mount drawer mounting

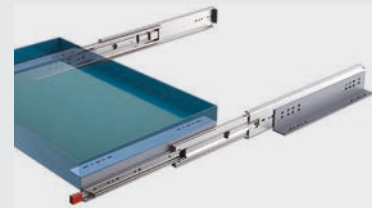

Slide Model	Slide Length		Bracket Length and Item No.			
			305 mm / 12 in.	406 mm / 16 in.	559 mm / 22 in.	711 mm / 28 in.
	mm	inch	5527	5528	5529	5530
5400	304.8	12	2 sets			
5400 / 5400L	355.6	14	2 sets			
5400 / 5400L	406.4	16		2 sets		
5400 / 5400L	457.2	18		2 sets		
5400 / 5400L	508.0	20		2 sets		
5400 / 5400L	558.8	22			2 sets	
5400 / 5400L	609.6	24			2 sets	
5400 / 5400L	660.4	26			2 sets	
5400 / 5400L	711.2	28				2 sets
5400 / 5400L	762.0	30				2 sets
5400 / 5400L	812.8	32				2 sets
5400 / 5400L	863.6	34	4 sets			
5400 / 5400L	914.4	36	4 sets			
5400 / 5400L	965.0	38	2 sets		2 sets	
5400	1,016.0	40	2 sets		2 sets	
5400L	1,016.0	40	3 sets		1 set	
5400	1,066.8	42	2 sets		1 set	1 set
5400L	1,066.8	42	3 sets			1 set
5400	1,117.6	44	2 sets		2 sets	
5400L	1,117.6	44	2 sets		1 set	1 set
5400	1,168.4	46	2 sets		2 sets	
5400L	1,168.4	46	2 sets		1 set	1 set
5400	1,219.2	48	2 sets			2 sets
5400L	1,219.2	48	3 sets			1 set
5400 / 5400L	1,270.0	50	3 sets			1 set
5400 / 5400L	1,320.8	52	2 sets	1 set		1 set
5400	1,371.6	54		1 set	3 sets	
5400L	1,371.6	54	1 set	1 set	2 sets	
5400 / 5400L	1,422.4	56	1 set		3 sets	
5400 / 5400L	1,473.2	58			3 sets	1 set
5400	1,524.0	60		1 set	2 sets	1 set
5400L	1,524.0	60		1 set	3 sets	

# FR 8100 | Locking Handle with Lock-In and Lock-Out



## Specifications

-  synthetic material, stainless steel

## Characteristics

- sold as kit, non-assembled
- for outdoor use and automotive applications
- push button release
- automatic lock-in and lock-out
- 30,000 cycles approved
- supporting drawer width up to 1,622 mm (63.86 in.)

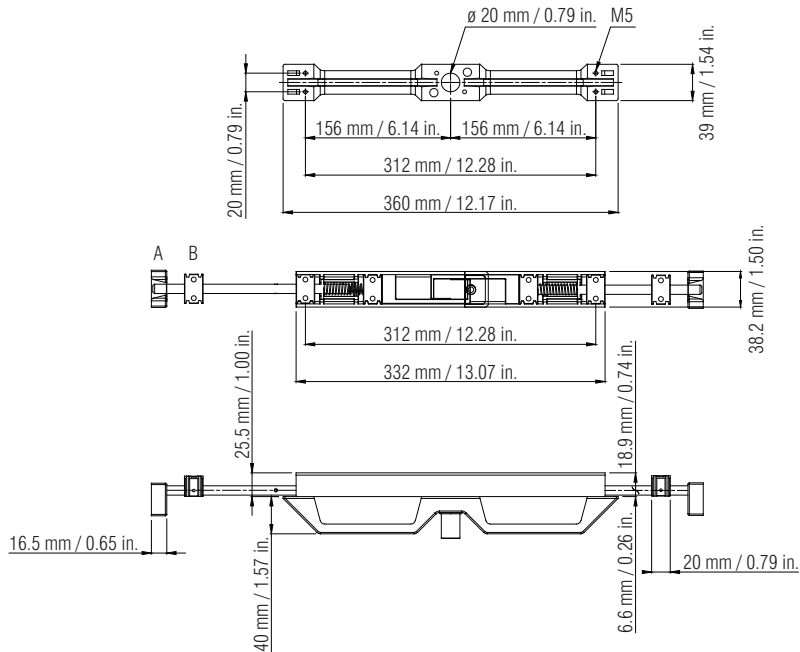
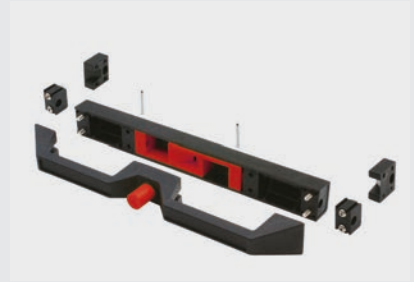

Designation	Weight		Item No.
	kg	lbs.	
Locking Handle with 2 pieces 500 mm (19.69 in.) stainless steel rods	1.70	3.75	*
Locking Handle with 2 pieces 750 mm (29.53 in.) stainless steel rods	2.10	4.63	*

Packing Unit – Set, all Lengths: 1

\* on request



**Legend on the inside.**

**Fulterer®**

**FULTERER Drawer Slide Systems 2023**

For general terms and conditions see:  
[www.fulterer.com](http://www.fulterer.com)

#### **IMPRINT**

Illustrations, dimensions and technical data shown in this catalogue are for illustrative purposes only and may be changed and adapted to new requirements at any time. We reserve the right to apply design changes and product modifications at any time. With the publication of this catalogue, all previous editions are no longer valid. We assume no liability for typographical and printing errors. All rights reserved. Use of texts and illustrations or reprints – also in extracts – only with our written permission. All deliveries are subject to the FULTERER Terms and Conditions of Sale, Delivery and Payment (GTC), which can be inspected on [www.fulterer.com](http://www.fulterer.com).

© FULTERER AG & Co KG – Lustenau, Austria 2022



## LEGEND

 bottom mount

 side mount

 top mount

 floor mount

 built-in width

 type of roller

 ball bearing cage

 material

 temperature range

 load capacity

 integrated ECD

 optional ECD

 NSF approved

## MOUNTING INSTRUCTIONS

Detailed mounting instructions, and technical drawings for all products on:

[www.fulterer.com](http://www.fulterer.com)



**FULTERER AG & CO KG**

Höchster Strasse 11  
Postfach 67  
6890 Lustenau  
AUSTRIA

T +43 5577 8130  
F +43 5577 8130 129  
info@fulterer.com  
www.fulterer.com

**FULTERER AG**

Industriestrasse 35  
9430 St. Margrethen  
SWITZERLAND

T +41 71 747 61 61  
F +41 71 747 62 29  
info@fulterer.com  
www.fulterer.com

**FULTERER USA, INC.**

542 Townsend Avenue  
High Point, NC 27263-4552  
USA

T +1 336 431 4646  
F +1 336 431 4620  
info@fultererusa.com  
www.fultererusa.com

**FULTERER USA, INC.**

1900 Proforma Avenue, Unit F-2  
Ontario, CA 91761  
USA

T +1 909 947 0407  
F +1 909 947 0409  
info@fultererusa.com  
www.fultererusa.com

**FULTERER MÉXICO**

**S. DE R.L. DE C.V**  
Av. Morelos 26-28  
CP 06040 Ciudad de México  
MEXICO

T +52 55 2345 3248  
info@fulterer.com  
www.fulterer.com

**FULTERER BRASIL EIRELI**

Avenida Sete de Setembro 5011,  
Cj. 802  
Água Verde  
80250-205 Curitiba/PR  
BRAZIL

brasil@fulterer.com  
www.fultererusa.com

**FULTERER GUANGZHOU  
TRADING CO., LTD.**

101 of Workshop, Building 1,  
No.13 Shinan Road,  
Dongchong Town  
Nansha District, Guangzhou City  
PEOPLES REPUBLIC OF CHINA

T +86 20 313 60 424  
china@fulterer.com  
www.fulterer.com

