

CABINET MOUNTING HOLES

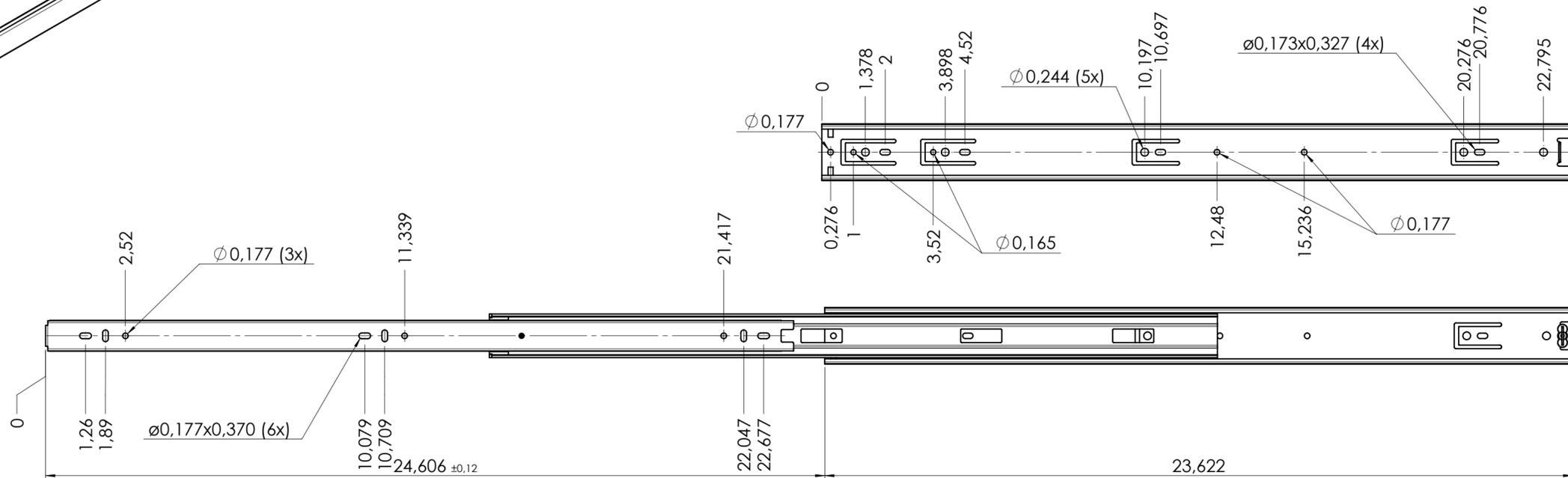

RECOMMENDED HARDWARE:

CABINET- 3.5mm SPAX M4 BUTTON HEAD OR #8 TRUSS HEAD SCREW

DRAWER- 3.5mm SPAX M4 BUTTON HEAD OR #8 TRUSS HEAD SCREW

general tolerances		stamping part according Fulterer W18-001		plastic part according DIN ISO 16742 TG4		DIN ISO 128-30 missing dimensions see 3D = theor. intersection	
This drawing remains our property and may not be multiplied neither be disclosed to third parties (§§1,3 and 5 from the copyright Act (UrhG)) covered according to DIN ISO 16016							
(k)				scale:	1:3	surface:	material, semi finished parts:
(l)				date	12-04-2022	name	Steel
(i)				drawn	CS		(technical requirements Fulterer)
(h)				proven	00-00-0000	00	description:
(g)				Fulterer			SIDE MOUNT OVER EXTENSION DRAWER SLIDE WITH DRAWER DISCONNECT
(f)				Fulterer AG & Co KG A-6890 Lustenau / Austria			drawing number:
(e)				Fulterer AG CH-9430 St. Margrethen			5046.600-GA.C030A
(d)							replaces version date:
(c)							
(b)							
(a)	0	00-00-0000	0				
ind.	changes	date	na.				