

CABINET MOUNTING HOLES

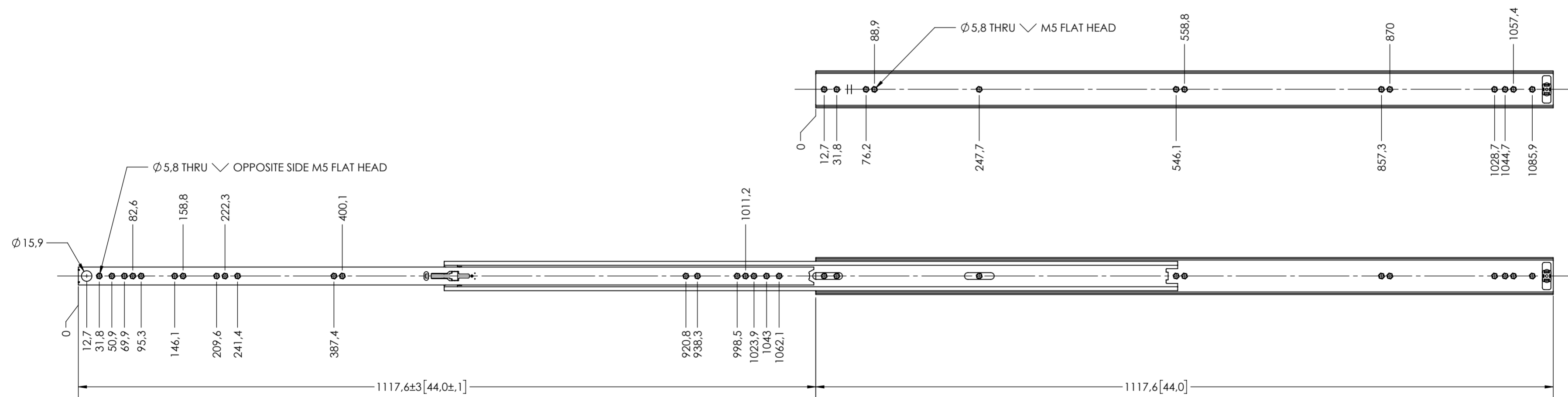

RECOMMENDED HARDWARE:

CABINET- M5 FLAT HEAD SCREW #10 FLAT HEAD SCREW

DRAWER- M5 FLAT HEAD SCREW OR #10 FLAT HEAD SCREW

general tolerances		DIN ISO 128-30 missing dimensions see 3D = theor. intersection	
ISO 2768-m			
This drawing remains our property and may not be multiplied neither be disclosed to third parties (§§1,3 and 5 from the copyright Act (UrhG)) covered according to DIN ISO 16016			
(k)	scale:	1:5	surface:
(l)	date	12-05-2020	name
(m)	drawn	MW	
(n)	proven	00-00-0000	00
(o)	Fullterer		material, semi finished parts:
(p)			STEEL
(q)			(technical requirements Fullterer)
(r)			description:
(s)			FULL EXTENSION SIDE MOUNT
(t)			DRAWER SLIDE WITH DRAWER
(u)			DISCONNECT
(v)			drawing number:
(w)			5609.44-GA.T055
(x)			replaces version date:
(y)	UPDATE TITLE BLOCK	19-03-2019	HB
(z)	ind. changes	date	na.