

PIONEERS OF MOTION

GASTRONOMY



Filterer[®]

EFFICIENT.
DURABLE.
RELIABLE.



01

PHILOSOPHY | VISION | COMPETENCE

The World of FULTERER	6
Our Company	8
Our Insight	10

02

PRODUCTS

Hygiene & Temperature Ranges	14
Modular variant tree	16
FR 795 SCC	18
PRECISION IN EVERY VERSION	
FR 7095 SCC	20
MODULARITY MEETS ROBUSTNESS	
FR 7195 SCC	22
WHEN THINGS GET REALLY HEAVY	
FR 1052 SCC	24
SLIM DESIGN. STRONG PERFORMANCE.	
ECD 79, ECD 709	26
WE'LL MAKE YOUR JOB A BIT EASIER.	

03

SERVICE, CERTIFICATIONS AND CONTACT

Product Information	30
Service & Contact	32

PHILOSOPHY | VISION | COMPETENCE

MOTION
WITH SUPREME
PRECISION



THE WORLD OF FULTERER

1956
The company is founded by Dr. Karl Fulterer.

1988
The family business is officially handed over to both sons Manfred and Heinz Fulterer.

1989
FULTERER USA, Inc. is established in High Point, NC, USA

2006
Ownership transfer of company shares to Manfred Fulterer

2007
Acquisition of Swiss Company Merz-Meyer AG

2016
A 1000 m² adjacent building for tool manufacturing is added to the headquarters in Lustenau, Austria.

2018
Implementation of a new lab for product development and testing

2019
FULTERER GUANGZHOU Trading CO., LTD. and FULTERER México S.DE R.L. DE C.V. are established in China and Mexico.

2020
A new 800-tonne punching and bending press is put into operation.

2022
Commissioning of a fully automatic assembly line for stainless steel rails in St. Margrethen

FULTERER BRASIL EIRELI is established.

2023
250 employees at eight locations in six countries

The company is 100% owned by the Fulterer family.

1956
ESTABLISHED

250
EMPLOYEES

CEO
SINCE 1988
MANFRED FULTERER

1,500
SATISFIED CUSTOMERS

25,000 M²
AREA OF PRODUCTION



6 / 7
COUNTRIES / LOCATIONS

AUSTRIA, LUSTENAU
 SWITZERLAND, ST. MARGRETHEN
 USA, HIGH POINT, NC
 USA, ONTARIO, CA
 CHINA, GUANGZHOU CITY
 MEXICO, CIUDAD DE MÉXICO
 BRAZIL, CURITIBA, PR

+10
AGENCIES

GERMANY, LAGE
 INDIA, BENGALURU
 ITALY, ZOPPOLA
 PORTUGAL, RIO TINTO
 SWEDEN, JONSTORP
 SWITZERLAND, ST. MARGRETHEN
 SPAIN, ALGORTA
 SOUTH KOREA, SEOUL
 CZECH REPUBLIC, PRAGUE
 VIETNAM, HANOI



FILTERER – PRECISION IN EVERY MOVEMENT

FILTERER

is a medium-sized company based in Lustenau, Austria and recognised as a the global leader in the production of drawer slides. We specialise in developing and producing premium drawer systems designed to enhance efficiency and convenience for our customers and partners. Our heavy-duty products serve as a dependable runway for all your projects – strong, reliable, and built to tackle any challenge.

Our company embodies flexibility and creativity – essential qualities for realising individual projects and ideas. We take pride in finding bespoke solutions to save you time and money, and quickly provide you with an ideal result.

FILTERER SERVICE

In addition to making our products faster, more efficient and simpler, the corresponding FILTERER service guarantees you smooth project handling and order processing. As part of our service commitment, we strive for a close relationship with our customers and provide timely on-site assistance.

A LEAP IN QUALITY FOR CUSTOMER PRODUCTS

To reach these goals, we build on the in-depth knowledge of our employees while continuously adapting and improving existing high-quality products. The modular FILTERER approach and manufacturing philosophy result in leap in quality for your product.

FILTERER

EXPLORE. DISCOVER. MOVE.

FILTERER – DYNAMIC EXPERIENCE

There are many reasons why our customers continue to place their trust in FILTERER, year after year. In addition to developing standard solutions since 1956, we also specialise in providing individual solutions. To achieve this, we tap into our extensive experience, which we share with our customers. Many of our products are customised solutions.

FLEXIBILITY AND SPEED

FILTERER is also defined by its flexibility. We are equipped with in-house tool manufacturing to provide solutions fast and in the required quality. To ensure that quality standards are reliably maintained, all our products are rigorously tested in-house.

KNOW-HOW AND EXPERIENCE

Another reason for choosing FILTERER is the know-how and experience of our specialists, who approach their work with enthusiasm. External testing and certifications continuously confirm our high quality standards.

FILTERER

WORLD OF MOTION

02

PRODUCTS

EXPLORE
THE WORLD
OF MOTION.

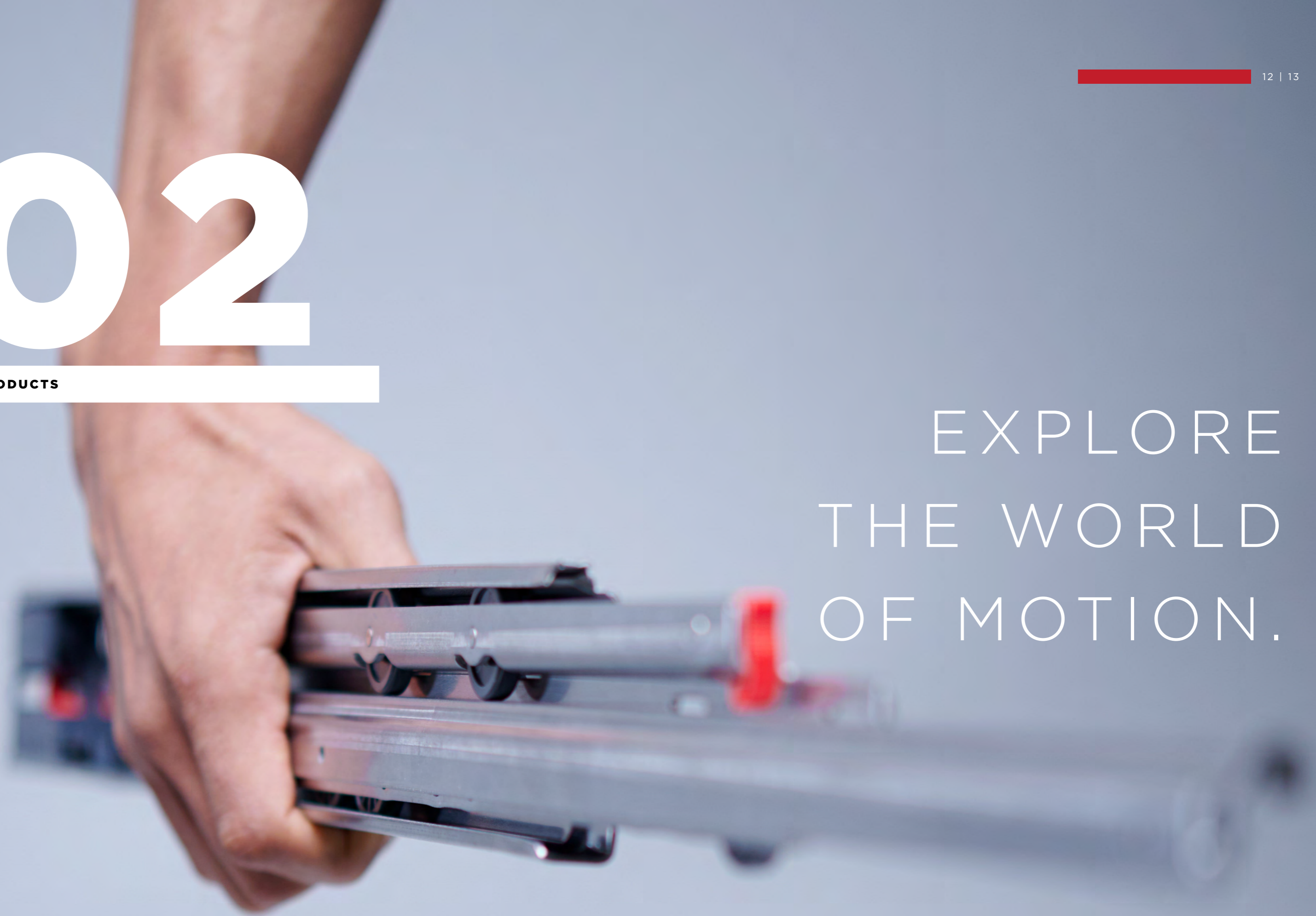

UN-COMPROMISING HYGIENE

FOR ALL THOSE WHO DEMAND THE HIGHEST STANDARDS OF CLEANLINESS



Whether in gastronomy or food production – wherever hygiene counts, there is a need for robust, easy-to-clean systems.

The Stainless Steel Drawer Slide Systems from Fulterer are corrosion-resistant, maintenance-free and fulfil international hygiene standards such as those of the NSF (National Sanitation Foundation). Their smooth surfaces are easy to clean – even in environments with high heat or moisture. For maximum cleanliness with minimum effort.

Cabinet profile

- easy to clean when the middle profile is removed
- no lubricant required
- maintenance-free

RELIABLE IN HEAT AND COLD

BETWEEN FREEZER TEMPERATURE AND HEAT EXPOSURE

Whether in a freezer, refrigerator or hot-air environment – the Stainless Steel Drawer Slide Systems from Fulterer function reliably in a wide range of temperatures. Without the ECD (Easy Close Device), application ranges from -40 to +110 °C (-104 to +230 °F) are possible (depending on product configuration). With the ECD, the tested temperature range is -25 to +40 °C (-13 to +104 °F). This ensures full functional reliability.

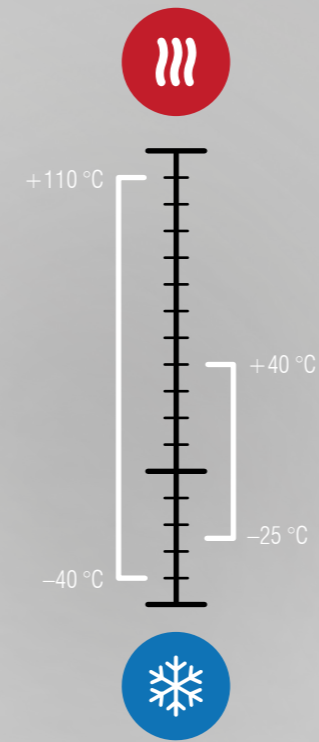

Middle profile

- easy to clean when removed
- no lubricant required
- maintenance-free



MODULARITY AT A GLANCE

VARIANT TREE USING FR 795 SCC AS AN EXAMPLE

What you see here is more than just a product. The modular structure of our Drawer Slide Systems allows drawer runners, centre runners and cabinet runners to be flexibly combined – depending on the mounting type or area of application.

The variant tree shown is an example of the possible combinations of the FR 795 SCC. Many of these variants are also available for related products such as the FR 7095 SCC or the FR 7195 SCC.

The result is a modular system that can be optimally integrated into your processes – efficient, sophisticated and future-proof.

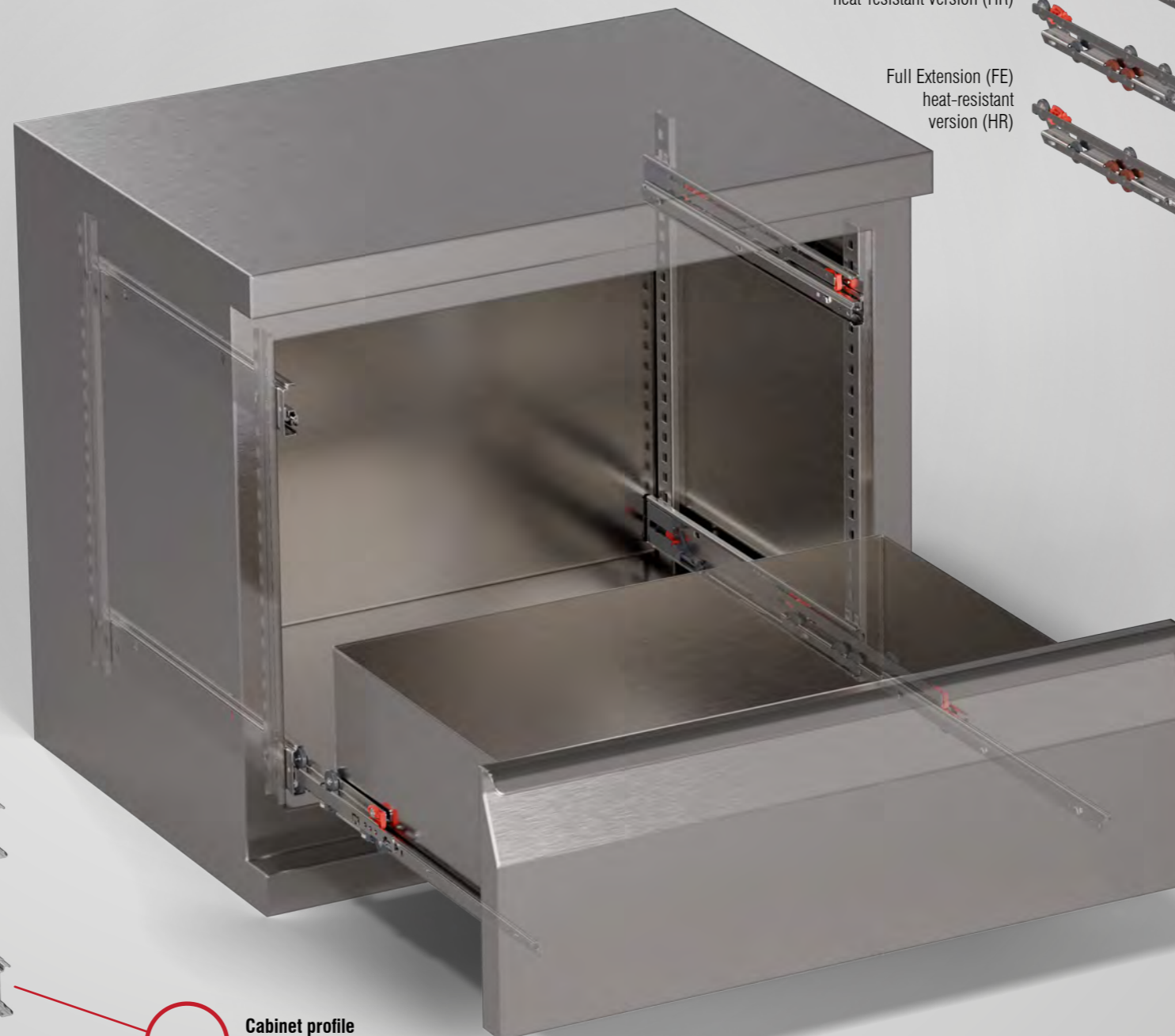

- Over Extension (OE) glider version
- Full Extension (FE) glider version
- Over Extension (OE) standard version
- Full Extension (FE) standard version
- Over Extension (OE) heat-resistant version (HR)
- Full Extension (FE) heat-resistant version (HR)

Middle profile

- easy to clean when removed
- no lubricant required
- maintenance-free

- side mounting without screw holes (welding)
- side mounting with screw holes
- side mounting with bayonet mounting tabs
- bottom mounting without screw holes (welding)
- bottom mounting with screw holes
- bottom mounting without screw holes (welding) with long leg for drawers with large corner radii

- without screw holes (welding)
- with screw holes
- with mounting tabs

Cabinet profile

- easy to clean when the middle profile is removed
- no lubricant required
- maintenance-free

Drawer profile

- synthetic stop
- dual-sided captive profile
- high lateral stability



PRECISION IN EVERY VERSION

FOR THE HIGHEST DEMANDS

Wherever hygiene, stability and durability are required – from commercial kitchens to food technology – the FR 795 SCC line sets new standards.



Drawer profile

- side or bottom mount
- synthetic stop
- dual-sided captive profile
- high lateral stability

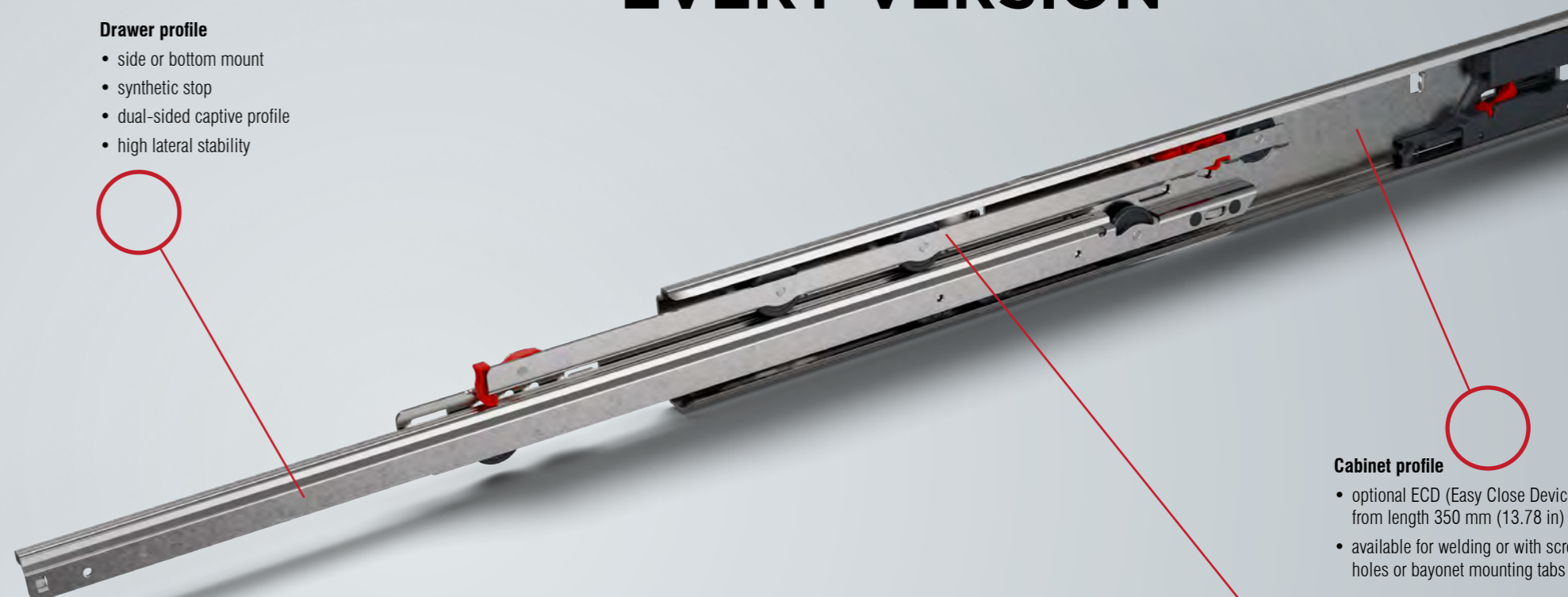

Cabinet profile

- optional ECD (Easy Close Device), from length 350 mm (13.78 in)
- available for welding or with screw holes or bayonet mounting tabs

Middle profile

- available as Full Extension (FE), Over Extension (OE) or as a Heat-Resistant (HR) variant up to +110 °C (+230 °F)
- integrated safety clip
- perfectly smooth runner motion thanks to integrated progressive action

FR 795 SCC PROGRESSIVE ACTION DRAWER SLIDES

The FR 795 SCC line stands for maximum flexibility: full extension or over-extension, screw mounting or quick assembly – always with high lateral stability and smooth running. Made of NSF-certified stainless steel and capable of bearing loads of up to 70 kg (154 lbs), it is impressive in all temperature ranges and can be perfectly supplemented with the optional Easy Close Device.

TECHNICAL DATA

FR 795 SCC (product family)

load capacity, dynamic up to	70 kg (154 lbs)
built-in width	18 mm (0.71 in)
slide height	62.5 mm (2.46 in)
length	300 to 750 mm (11.81 to 29.53 in)
temperature range	-40 to +110 °C (-104 to +230 °F)



STRONG. FLEXIBLE. RELIABLE.

Wherever high load capacity, modular solutions and temperature resistance are required – from the refrigeration sector to the food processing industry – the FR 7095 SCC impresses with its robust technology and versatility.



Drawer profile

- side or bottom mount
- synthetic stop
- dual-sided captive profile
- high lateral stability



Cabinet profile

- optional ECD (Easy Close Device), from length 350 mm (13.78 in)
- available for welding or with screw holes or bayonet mounting tabs



FR 7095 SCC PROGRESSIVE ACTION DRAWER SLIDES

The FR 7095 SCC harmonises power and versatility. With a dynamic load capacity of up to 120 kg (265 lbs), it is ideal for applications with increased weight – whether in gastronomy, refrigeration or food service. New integrated lift out prevention provides reliable protection and locks automatically during assembly.

Middle profile

- available as Full Extension (FE), Over Extension (OE) or as a Heat-Resistant (HR) variant up to +110 °C (+230 °F)
- new lift out prevention: locks automatically during assembly
- perfectly smooth motion thanks to integrated progressive action



TECHNICAL DATA

	FR 7095 SCC (product family)
load capacity, dynamic up to	120 kg (265 lbs)
built-in width	24 mm (0.94 in)
slide height	62.5 mm (2.46 in)
length	400 to 750 mm (15.75 to 29.53 in)
temperature range	-40 to +110 °C (-104 to +230 °F)



MADE FOR EXTREME LOADS

Whether for use in the freezer area or with heavy kitchen drawers – the FR 7195 SCC carries up to 180 kg confidently and reliably. Maximum load capacity, maximum safety, maximum performance.



Drawer profile

- side or bottom mount
- synthetic stop
- dual-sided captive profile
- high lateral stability



Cabinet profile

- optional ECD (Easy Close Device), from length 350 mm (13.78 in)
- available for welding or with screw holes or bayonet mounting tabs



FR 7195 SCC HEAVY-DUTY FULL EXTENSION DRAWER SLIDES

The FR 7195 SCC is the uncompromising solution for the highest loads in demanding everyday use. With a dynamic load capacity of up to 180 kg (396 lbs) in full extension, it is the most powerful pull-out system in the Fullerer stainless steel range – ideal for highly demanding applications in the gastronomy and food industries, and for refrigeration applications.



Middle profile

- available as Full Extension (FE), Over Extension (OE) or as a Heat-Resistant (HR) variant up to +110 °C (+230 °F)
- new lift out prevention: locks automatically during assembly
- perfectly smooth runner motion thanks to integrated progressive action

TECHNICAL DATA

FR 7195 SCC (product family)

load capacity, dynamic up to	180 kg (396 lbs)
built-in width	24 mm (0.94 in)
slide height	62.5 mm (2.46 in)
length	400 to 1000 mm (15.75 to 39.37 in)
temperature range	-40 to +110 °C (-104 to +230 °F)





SLIM DESIGN. STRONG PERFORMANCE.

PRECISION IN THE TIGHTEST OF SPACES

Reliable stainless steel Regular Extension Drawer Slide for demanding applications – wherever maximum stability and hygiene are required in confined spaces.



Drawer profile

- single-sided captive profile (right)
- rear backstop
- self-closing
- high lateral stability

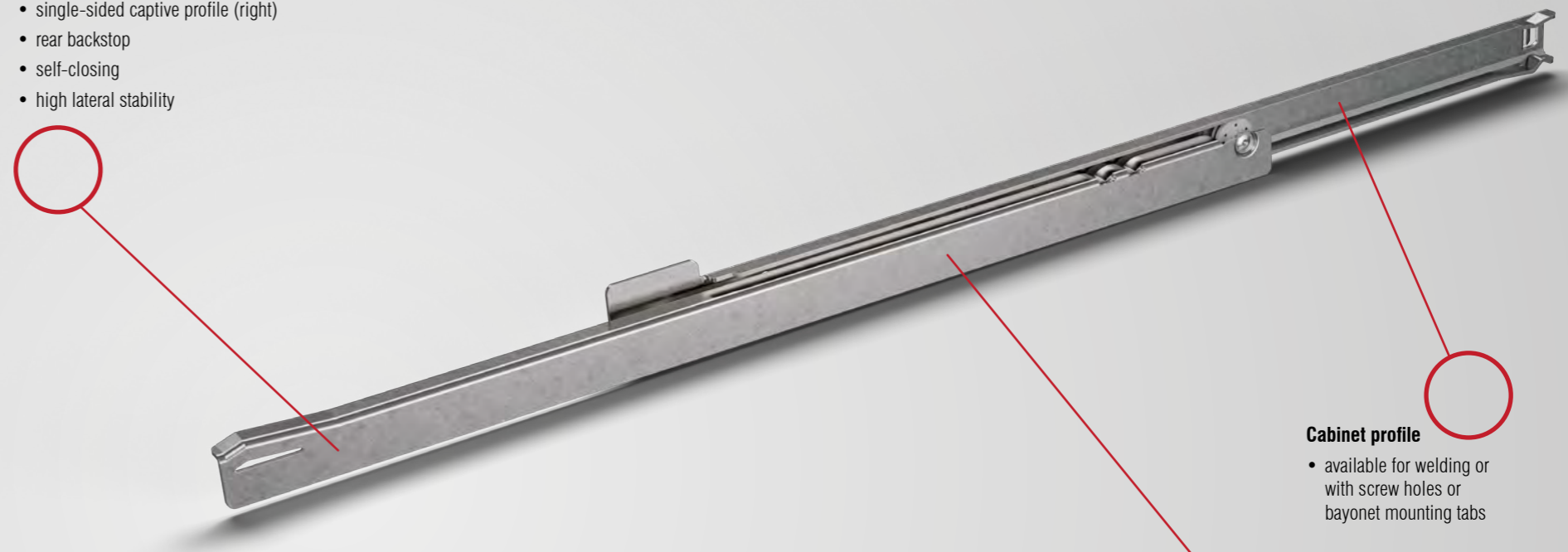

Cabinet profile

- available for welding or with screw holes or bayonet mounting tabs



FR 1052 SCC REGULAR EXTENSION DRAWER SLIDES WITH LATERAL STABILITY

With a built-in width of only 18 mm (0.71 in), the FR 1052 SCC is one of the slimmest Regular Extension Drawer Slides with Lateral Stability made of stainless steel – perfect for tight installation spaces with high demands in terms of stability, hygiene and temperature resistance. The drawer slide has a single-sided captive profile, features a rear backstop and closes reliably thanks to its self-closing mechanism.



Your benefit

- compatible with Full Extension Drawer Slide FR 795 SCC

TECHNICAL DATA

	FR 1052 SCC (product family)
load capacity, dynamic up to	50 kg (110 lbs)
built-in width	15 and 18 mm (0.59 and 0.71 in)
slide height	39.5 mm (1.56 in)
length	400 to 750 mm (15.75 to 29.53 in)
temperature range	-40 °C to +210 °C (-104 °F to +410 °F)



WE'LL MAKE YOUR JOB A BIT EASIER.

The FULTERER Easy Close Device system ensures smooth, quiet closing – even when fully loaded. Depending on the system, the appropriate Easy Close Device (ECD) is used: ECD 79 for 18 mm, ECD 709 for 24 mm built-in width.

FULTERER – FOR MORE COMFORT ON THE JOB

ECD 79 EASY CLOSE DEVICE RETROFIT-KIT

Compact, quiet, efficient: the ECD 79 is the appropriate easy close system for all 18 mm rails such as the FR 795 SCC. It offers gentle self-closing, can be retrofitted without tools and works reliably from -25 to +40 °C (-13 to +104 °F).

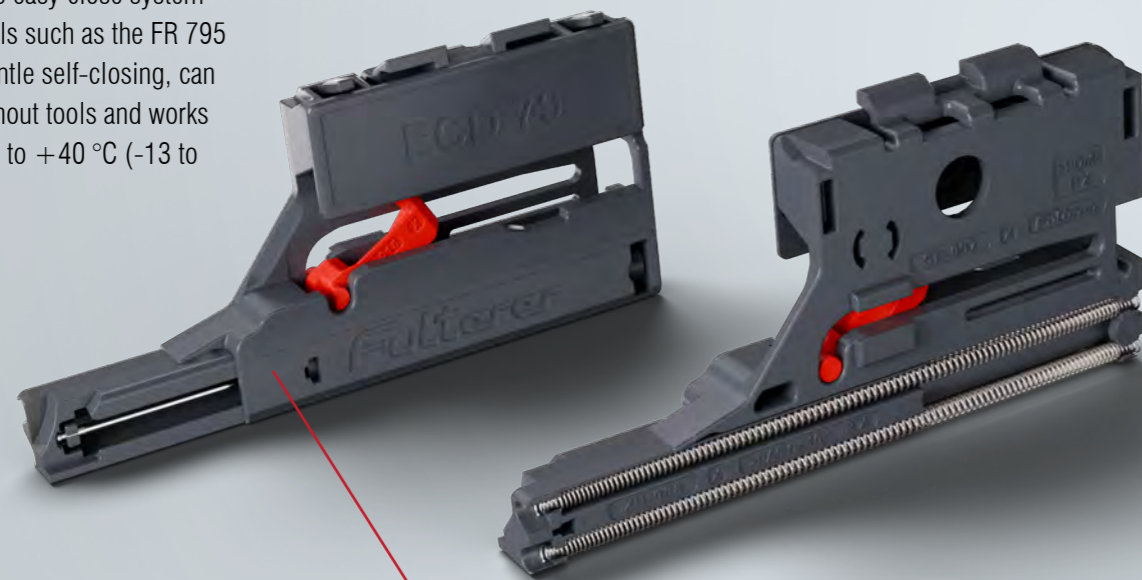

Properties

- dynamic up to 70 kg (154 lbs)
- assembly using a plug-in system
- can be retrofitted as a set at any time from length 350 mm (13.78 in)
- The slide is slowed down before reaching the stop and closes reliably, automatically, gently and silently.
- The easy close / self-closing and slam-resistant function is not compromised by varying load conditions.
- temperature range -25 to +40 °C (-13 to +104 °F)

ECD 709 EASY CLOSE DEVICE RETROFIT-KIT

Robust and versatile: the ECD 709 is the easy close system for all 24 mm rails such as the FR 7095 SCC. It offers gentle self-closing, can be retrofitted on both sides without tools and works reliably in a temperature range from -25 to +40 °C (-13 to +104 °F). The reinforced ECD 709-S variant is available for heavy loads over 80 kg (176 lbs) – at temperatures from +10 to +40 °C (50 to 104 °F).

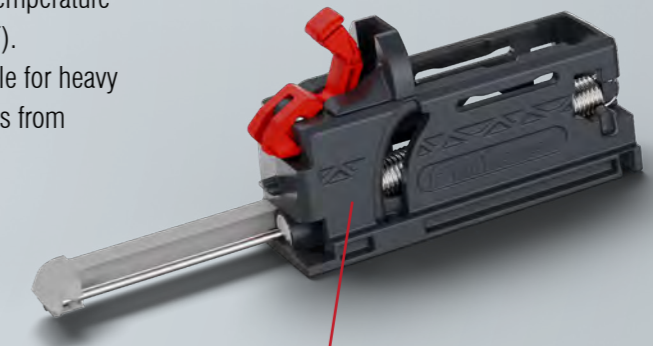

Properties

- dynamic up to 180 kg (396 lbs)
- assembly using a plug-in system
- can be retrofitted as a set at any time
- The slide is slowed down before reaching the stop and closes reliably, automatically, gently and silently.
- The easy close / self-closing and slam-resistant function is not compromised by varying load conditions.
- temperature range -25 to +40 °C (-13 to +104 °F)

03

SERVICE, CERTIFICATIONS AND CONTACT



YOUR
SERVICE IS
OUR FOCUS

FILTERER STANDS FOR EXCELLENCE

In addition to the high quality of its products, FILTERER also offers customers the flexibility and creativity required to accommodate individual projects and ideas, and ensures their successful implementation.

The corresponding FILTERER service guarantees you smooth project handling and order processing. Achieving this requires both the solid expertise of our team and our commitment to continuous product development.

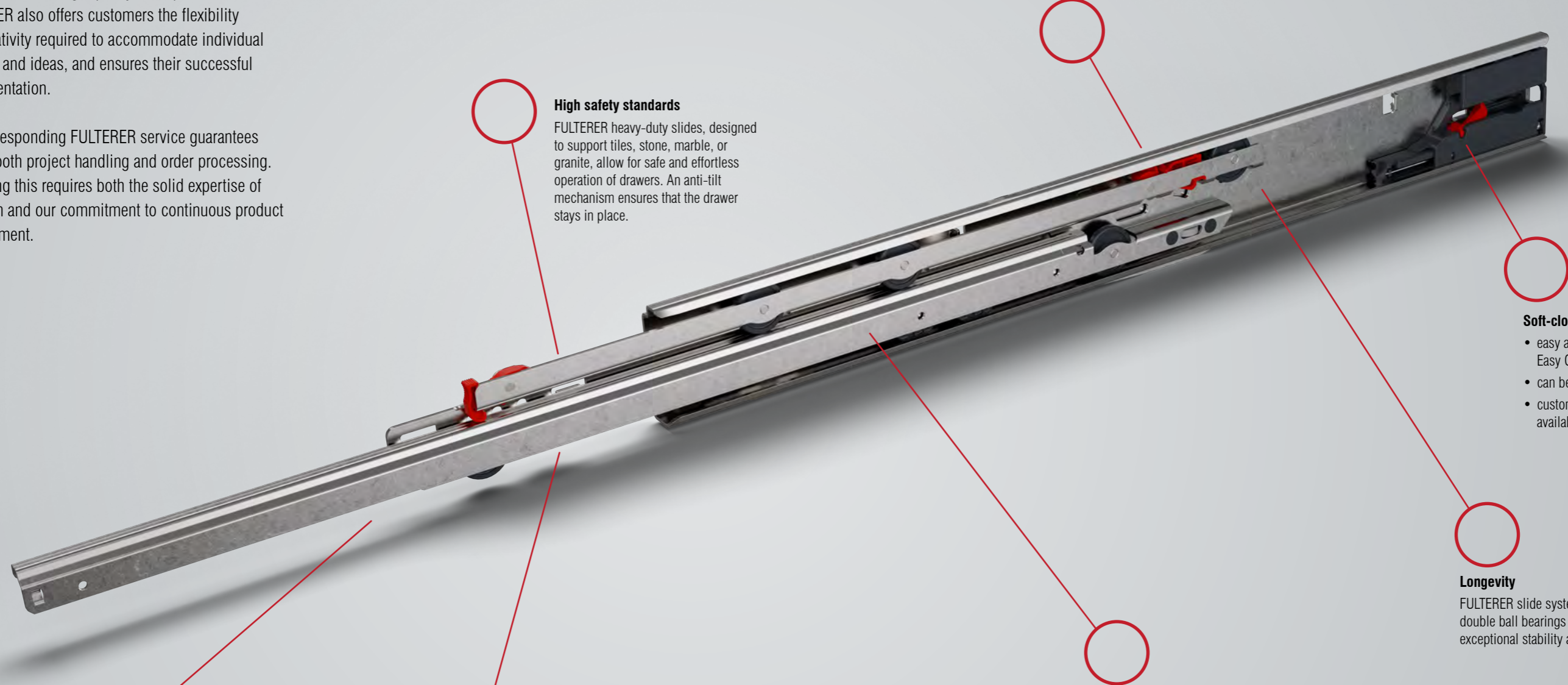

High safety standards

FILTERER heavy-duty slides, designed to support tiles, stone, marble, or granite, allow for safe and effortless operation of drawers. An anti-tilt mechanism ensures that the drawer stays in place.

Easy cleaning and maintenance

Since FILTERER slide systems require no lubrication, they are practically maintenance-free. They are also very easy to clean.

Soft-close mechanism

- easy assembly of the FILTERER Easy Close Device
- can be retrofitted as a set at any time
- customisable, with a wide range of available colour options

Longevity

FILTERER slide systems feature double ball bearings that provide exceptional stability and longevity.

International standards

FILTERER slide systems are compliant with international requirements and quality standards, and backed by numerous certifications to ensure reliable operation around the world.

Certifications

 NSF (National Sanitation Foundation)

 TÜV AUSTRIA – Quality Management

 RoHS Compliant

 REACH Compliant

 ÖKOPROFIT Betrieb 2025

FILTERER **accessories** simplify your daily work. Drawer locks are designed to prevent unwanted chaos. The soft-close mechanism minimises the effort required for operation. Custom colour options are available. Various solutions can be retrofitted.

EMAIL

Do you have questions, requests, suggestions? Discover the possibilities FULTERER has in store for you. Email us for further assistance.

> sales@fulterer.com

PHONE

Do you have questions? Contact us by phone and we can discuss your request.

> +43 5577 8130

WEBSITE

Discover the FULTERER world. All products, services and company information at a glance.

> www.fulterer.com

YOUR INDIVIDUAL
REQUEST IS OUR
SERVICE:
**FEEL FREE TO
CONTACT US**



SERVICE THAT MATTERS

Do you have questions about our products? Looking for special solutions?

We look forward to hearing from you.



FULTERER EUROPE

FULTERER AG & CO KG

Höchster Strasse 11
Postfach 67
6890 Lustenau
AUSTRIA

T +43 5577 8130
info@fulterer.com
www.fulterer.com

FULTERER AG

Industriestrasse 35
9430 St. Margrethen
SWITZERLAND

T +41 71 747 61 61
info@fulterer.com
www.fulterer.com

FULTERER WORLDWIDE

FULTERER USA, INC.

542 Townsend Avenue
High Point, NC 27263-4552
USA

T +1 336 431 4646
info@fultererusa.com
www.fultererusa.com

FULTERER USA, INC.

1900 Proforma Avenue, Unit F-2
Ontario, CA 91761
USA

T +1 909 947 0407
info@fultererusa.com
www.fultererusa.com

FULTERER MÉXICO

S. DE R.L. DE C.V

Av. Morelos 26-28
CP 06040 Ciudad de México
MEXICO

T +52 55 2345 3248
mexico@fulterer.com
www.fulterer.com

FULTERER BRASIL EIRELI

Avenida Sete de Setembro 5011,
Cj. 802 | Água Verde
80250-205 Curitiba/PR
BRAZIL

T +55 41 99263 5066
brasil@fulterer.com
www.fulterer.com

FULTERER GUANGZHOU TRADING CO., LTD.

101 of Workshop, Building 1,
No.13 Shinan Road,
Dongchong Town
Nansha District, Guangzhou City
PEOPLES REPUBLIC OF CHINA

T +86 20 3136 0424
china@fulterer.com
www.fulterer.com