

DRAWER WIDTH = CABINET OPEING WIDTH - 10mm
WITH 16mm WALL THICKNESS

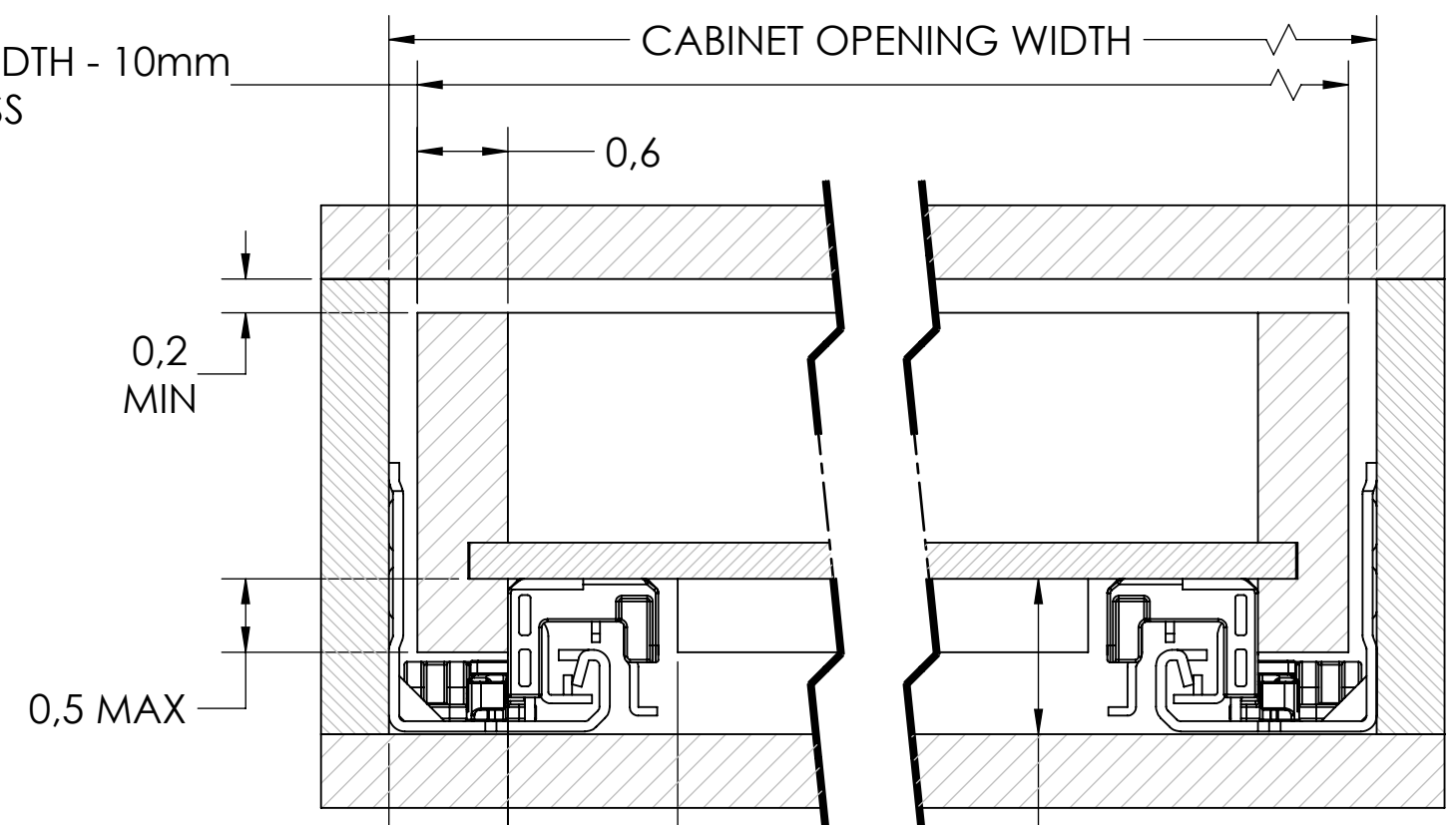

SCALE 3:4

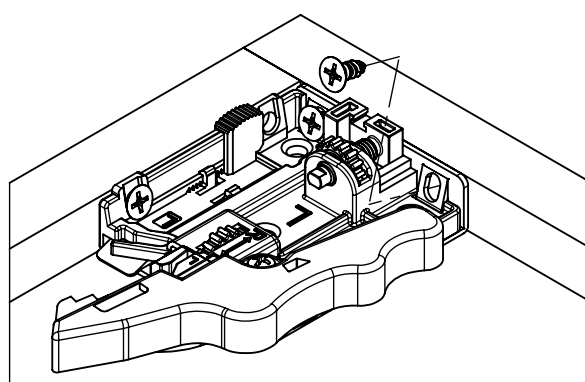

LOCKING KIT
FRONT/SIDE MOUNT
SCALE 1:1.5

CABINET MOUNTING HOLES

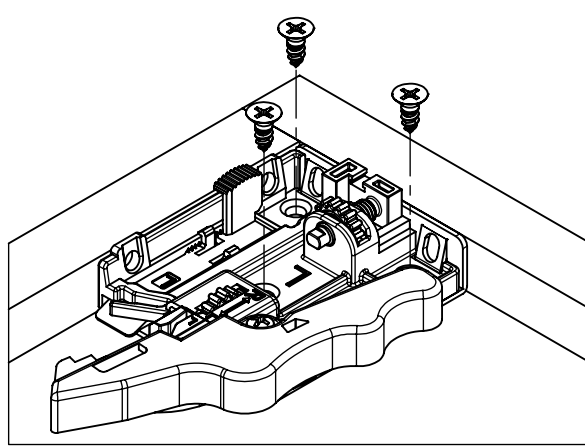
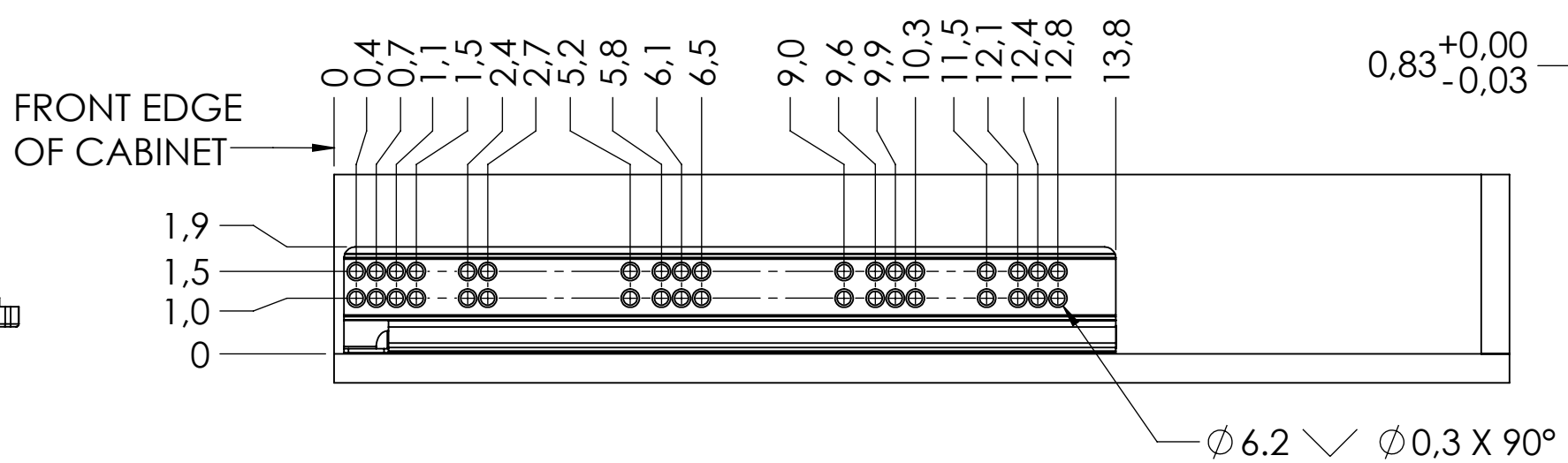

LOCKING KIT
BOTTOM MOUNT
SCALE 1:1.5

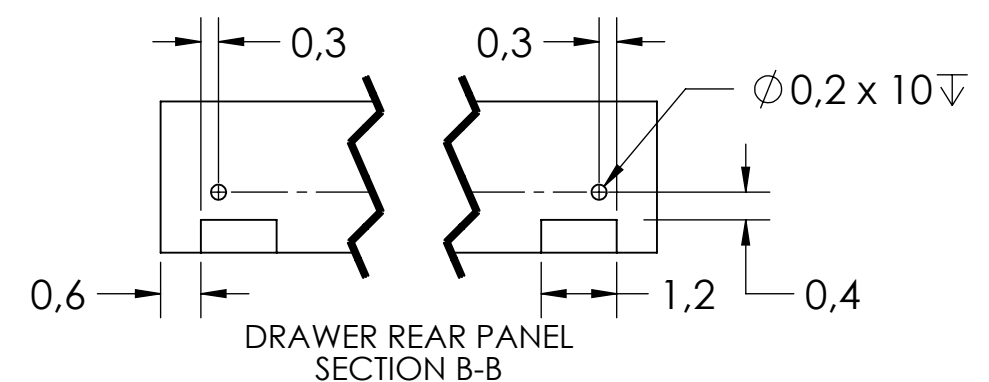
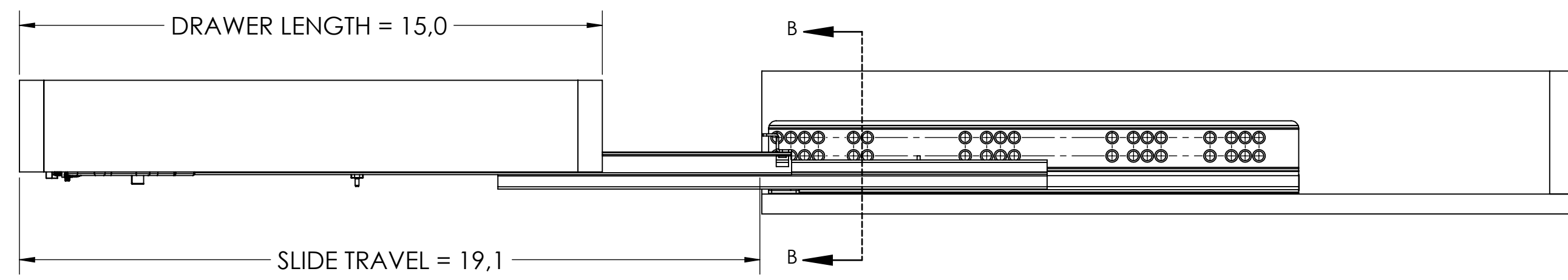
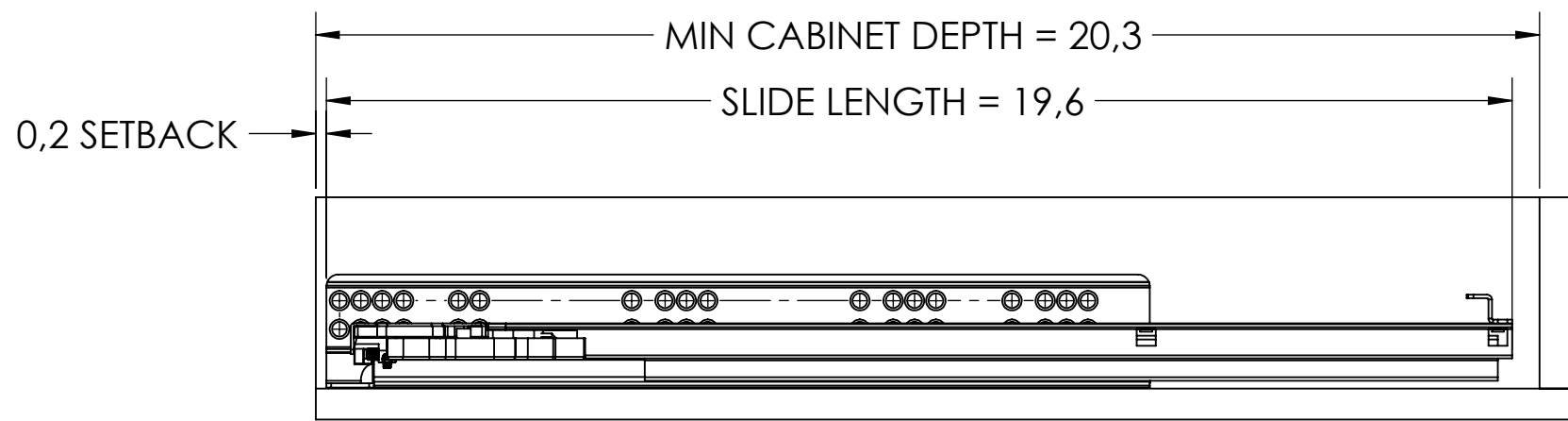

RECOMMENDED HARDWARE:

CABINET- M4 OR #6 FLATHEAD SCREWS

DRAWER LOCKING KIT- M3 OR #6 FLATHEAD SCREW

NOTE: LOCKING KIT INCLUDED WITH SLIDE

general tolerances		DIN ISO 128-30 missing dimensions see 3D = theor. intersection	
ISO 2768-m			
This drawing remains our property and may not be multiplied neither be disclosed to third parties (§§1,3 and 5 from the copyright Act (UrhG))			
covered according to DIN ISO 16016		scale:	surface:
(k)		1:3	
(l)		date	name
(m)		drawn 24-04-2019	HB
(n)		proven 00-00-0000	00
(o)		Fulterer	
(p)			
(q)		Fulterer AG & Co KG A-6890 Lustenau / Austria	
(r)		Fulterer AG CH-9430 St. Margrethen	
(s)		drawing number: 3002.500-GA.C047	
(t)		replaces version date:	
(u)			
(v)			
(w)			
(x)			
(y)			
(z)			
ind.	changes	date	na.