

# 5000.250-GA.T000

X

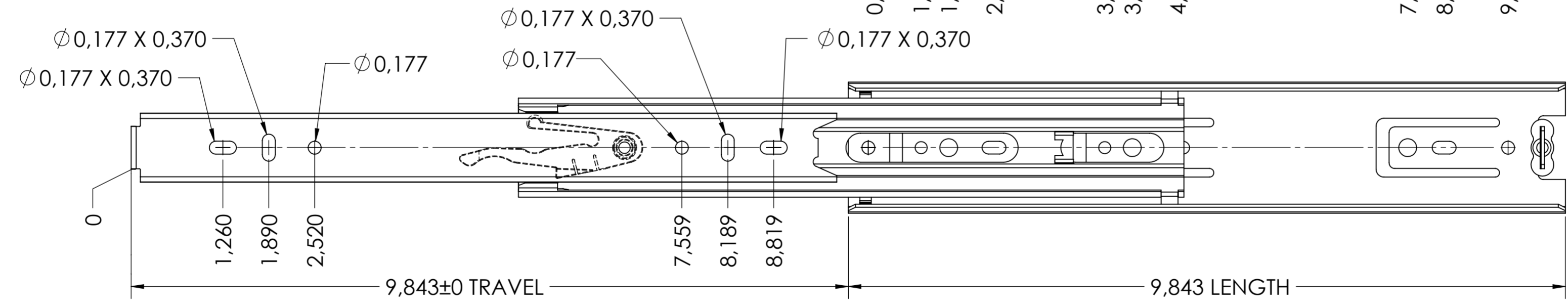
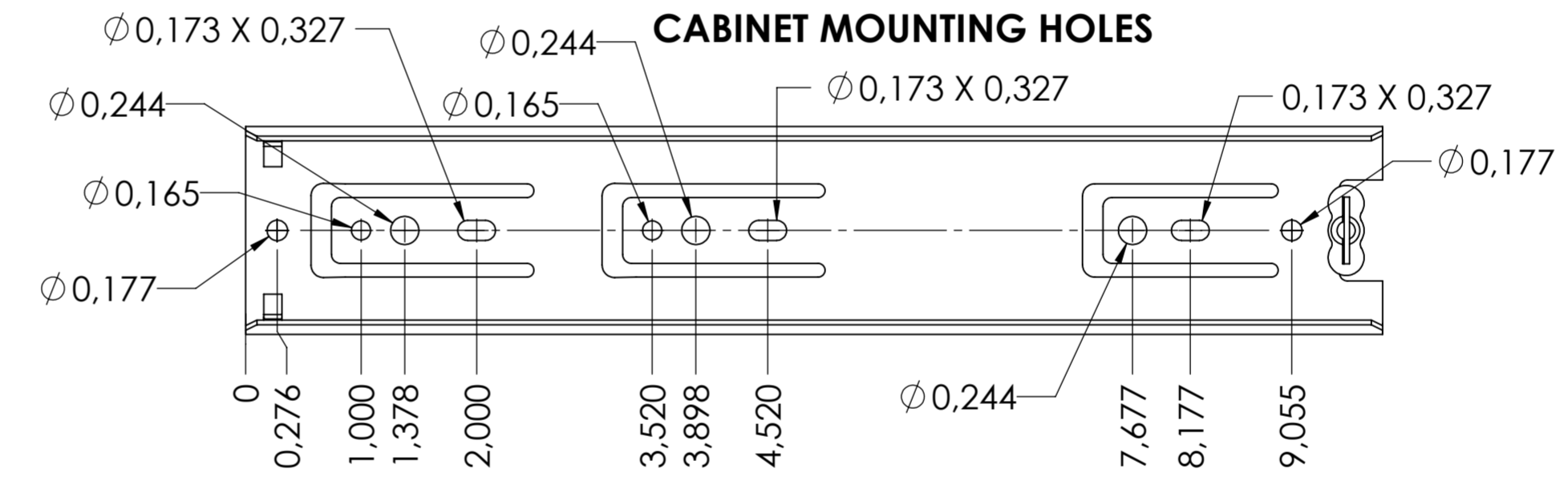
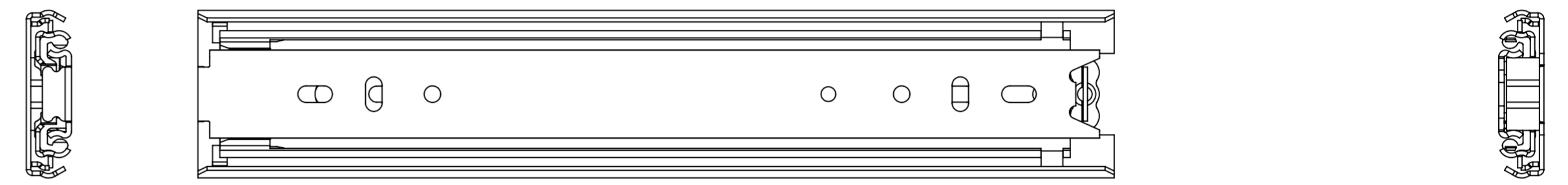
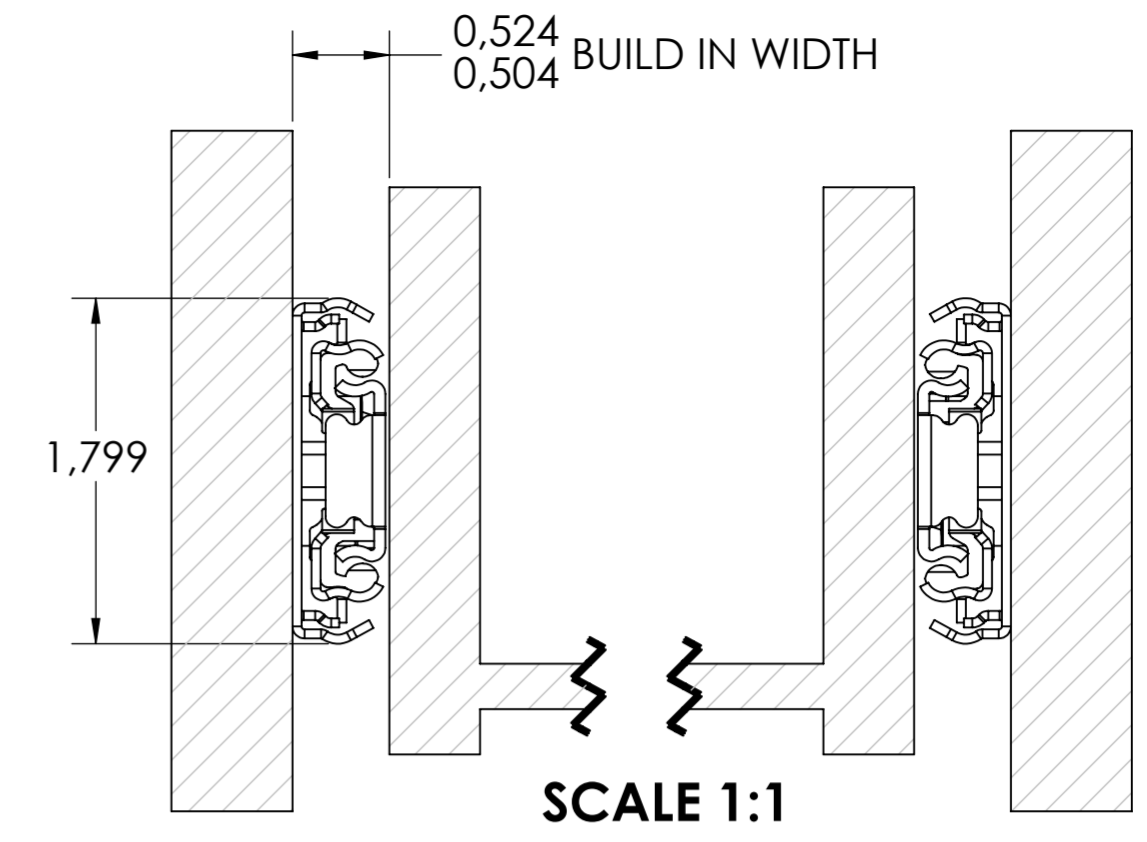
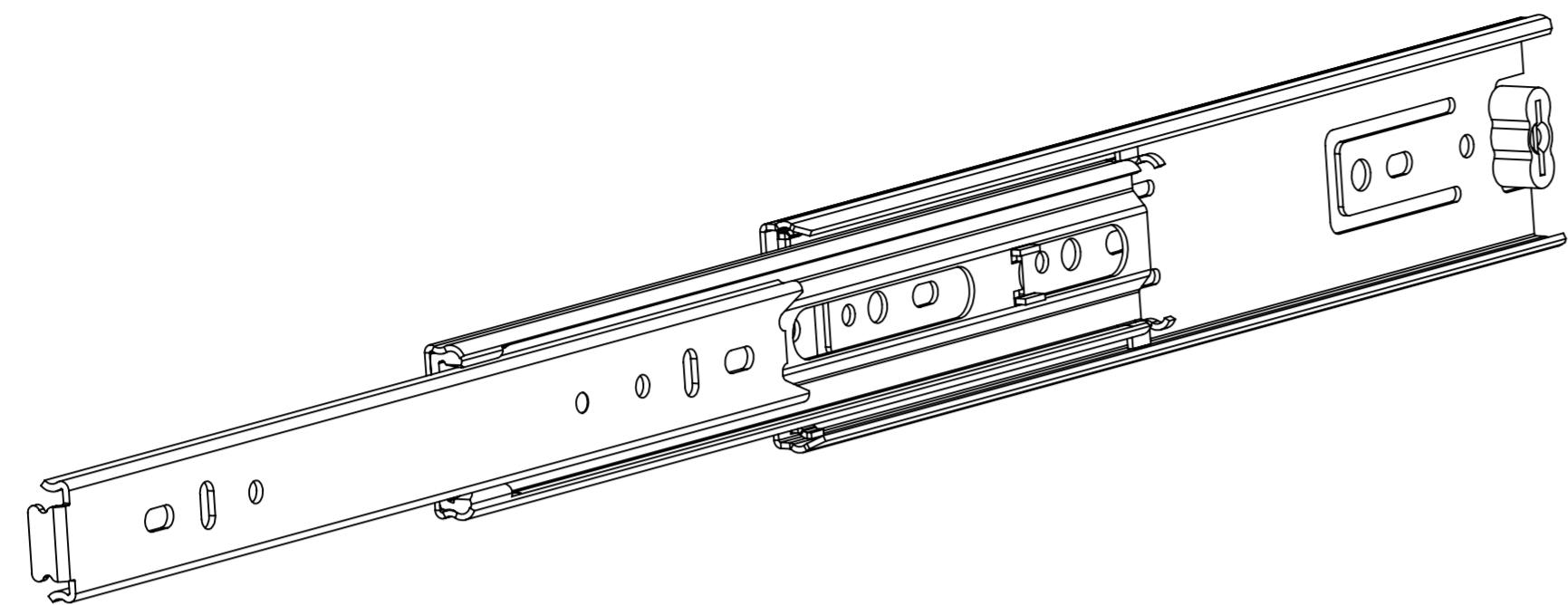

RECOMMENDED HARDWARE:  
 CABINET- M4 BUTTON HEAD OR #8 TRUSS HEAD SCREW  
 DRAWER- M4 BUTTON HEAD OR #8 TRUSS HEAD SCREW

general tolerances		missing dimensions see 3D = theor. intersection	
ISO 2768-m			
This drawing remains our property and may not be multiplied neither be disclosed to third parties (§§1,3 and 5 from the copyright Act (UrhG)) covered according to DIN ISO 16016			
(k)	scale:	3:4	surface:
(l)	date:	28-09-2018	name:
(m)	drawn:	HB	description:
(n)	proven:	00-00-0000	00
(o)	<b>Fulterer</b>		FULL EXTENSION SIDE MOUNT DRAWER SLIDE WITH DRAWER DISCONNECT
(p)			
(q)	Fulterer AG & Co KG		drawing number: <b>5000.250-GA.T000</b>
(r)	A-6890 Lustenau / Austria		
(s)	Fulterer AG		replaces version date:
(t)	CH-9430 St. Margrethen		
(u)	changes	date	na.