

CABINET MOUNTING HOLES

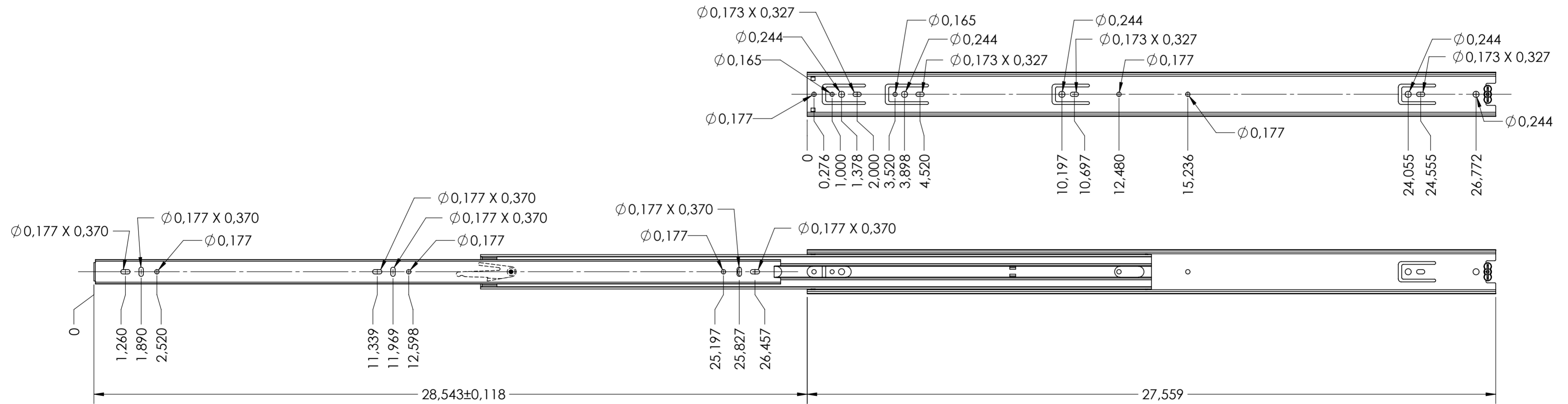

RECOMMENDED HARDWARE:
 CABINET- 3.5mm SPAX M4 BUTTON HEAD OR #8 TRUSS HEAD SCREW
 DRAWER- 3.5mm SPAX M4 BUTTON HEAD OR #8 TRUSS HEAD SCREW

general tolerances		DIN ISO 128-30 missing dimensions see 3D = theor. intersection	
ISO 2768-m			
This drawing remains our property and may not be multiplied neither be disclosed to third parties (§§1,3 and 5 from the copyright Act (UrhG)) covered according to DIN ISO 16016			
(k)	scale:	1:3	surface:
(l)	date:	03-09-2020	name:
(m)	drawn:	CS	description:
(n)	proven:	00-00-0000	00
(o)			material, semi finished parts: STEEL (technical requirements Fulterer)
(p)			drawing number: 5045.700-GA.C030A
(q)	Fulterer AG & Co KG A-6890 Lustenau / Austria Fulterer AG CH-9430 St. Margrethen		replaces version date:
(r)	ind.	changes	date na.