

FR 9001 Lock & Stop | for FR 9001

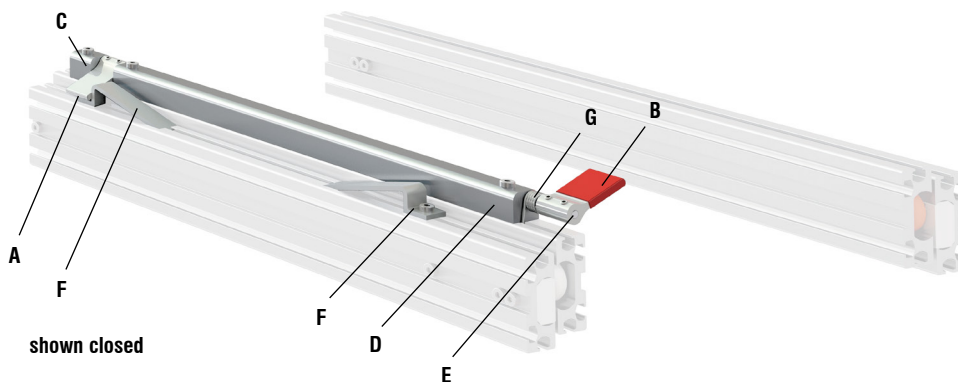

Specifications

aluminium and steel

Characteristics

- lock & stop system for use with FR 9001 aluminum slide system
- consisting of:
1 piece Lock lever (A), 1 piece Release lever (B), 1 piece Rod guide (C), 2 pieces Ramp (F), 1 piece Spring (G), 4 pieces Set screws M5 x 6 mm, 3 pieces Bolt

Type		Weight		Item No.
		per set		
Lock & Stop		kg	lbs.	9202
Profile D Extrusion	Length 6,400.0 mm / 251.97 in.	*	*	92018
Profile D Extrusion	Length 25.4 mm / 1.00 in.	*	*	92018C
Rod E	Length 400.0 mm / 15.75 in.	*	*	92021

Packing Unit – Set: 1

* on request